



P220G AND P220GS SERIES VALVES



Learn more at
[toro.com](https://www.toro.com)

The P220G and P220GS Series provide a full family of plastic valves that can deliver the water to meet the challenging needs of today's courses. With precise pressure regulation these valves deliver the optimum pressure and flow requirements to every sprinkler on the zone ensuring maximum uniformity of the water to the turf.



P220G AND P220GS SERIES VALVES

Features & Benefits

- ① **EZReg® Pressure Regulating System**
Can be adjusted from 0,3-6,9 Bar (5-100 PSI) to deliver the optimum pressure for every need.
- ② **Spike Guard™ Solenoid**
With its 20,000 volt lightning rating, it virtually eliminates the need for solenoid replacements in high lightning environments.

- ③ **Internal Manual Bleed**
Ensures the optimum pressure of the system even when being operated manually.
- ④ **Double-beaded Fabric Reinforced Diaphragm**
Provides superior performance and extended life without tearing in high-pressure golf applications.

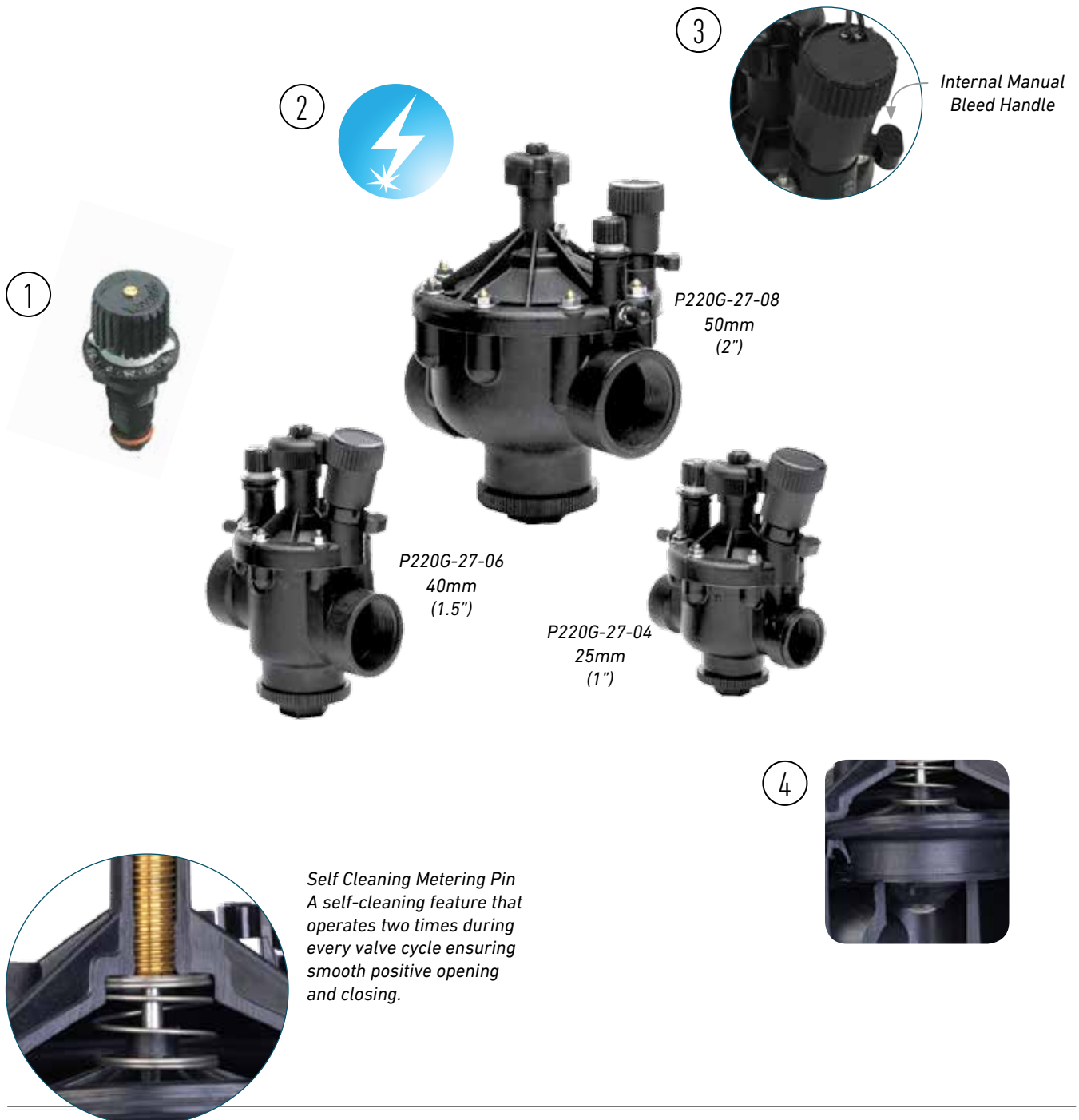

P220G AND P220GS SERIES VALVES

Valve Wire Sizing Chart

Maximum One-way Distance (in meters) Between Controller and Valve Using Spike-Guard™ Solenoid*

Ground Wire	Control Wire						
	18	16	14	12	10	8	6
18	622	768	896	1000	1079	1134	1177
16	768	993	1219	1420	1591	1713	1804
14	896	1219	1579	1939	2262	2530	2731
12	1000	1420	1939	2512	3078	3597	4017
10	1079	1591	2262	3078	4017	4895	5721
8	1134	1603	2530	3597	4895	6340	7785
6	1122	1817	2731	4017	5700	7785	10083

* Solenoid Model: 24 V ac
 Pressure: 10,3 Bar (150 psi)
 Voltage Drop: 4 V
 Minimum Operating Voltage: 20 V
 Amperage (peak) 0.12 A

Operating Specifications

- Flow Range:
 - 25mm (1"): 18,9-189,3 LPM (5-50 GPM)
 - 40mm (1.5"): 113,6 - 416,4 LPM (30 - 110 GPM)
 - 50mm (2"): 302,8 - 681,4 LPM (80 - 180 GPM)
- Operating Pressure: 15,2 bar (220 psi) maximum pressure rating
 - Electric: 0,7 - 15,2 bar (10 - 220 psi)
- Pressure regulating:
 - Outlet: 0,3 - 6,9 bar (5 - 100 psi ± 3 psi)
 - Inlet: 0,7 - 15,2 bar (10 - 220 psi)
- Minimum pressure differential (between inlet and outlet) for pressure regulation: 0,7 bar (10 psi)
- Burst pressure safety rating: 51,7 bar (750 psi)
- Body styles:
 - Globe/Angle: 25mm, 40mm, and 50mm (1", 1.5", 2") female threads
- Spike Guard™ Solenoid: 24 VAC (50/60 Hz) Standard
 - Inrush: 60 Hz; 0,12 amps
 - Holding: 60 Hz; 0,1 amps

Additional features

- Glass-filled nylon and stainless steel construction
- Internal and External bleed
- No external tubing
- Standard, built-in Schrader-type valve for downstream pressure verification
- Flow control independent of solenoid
- Self-aligning bonnet to ensure correct installation
- Self-cleaning, stainless steel metering rod
- Low-flow capability down to 5 GPM
- Low-power requirement for longer wire runs

Dimensions

- 25mm (1"): 146 x 127mm (5.75" H x 5" W)
- 40mm (1.5"): 165 x 152mm (6.5" H x 6" W)
- 50mm (2"): 191 x 178mm (7.25" H x 7" W)

Warranty

- Two years

P220G Series Friction Loss Data—(Metric)

Size	Configuration	LPM Flow																
		25	50	75	100	125	150	200	250	300	350	400	450	500	600	700	800	900
25mm (1")	Globe	0,28	0,29	0,22	0,28	0,50												
	Angle	0,28	0,29	0,21	0,19	0,33												
40mm (1.5")	Globe				0,11	0,16	0,25	0,36	0,48	0,63	0,77	0,94	1,13					
	Angle				0,09	0,11	0,19	0,28	0,36	0,49	0,61	0,75	0,93					
50mm (2")	Globe									0,14	0,19	0,23	0,28	0,33	0,39	0,45	0,52	0,60
	Angle									0,08	0,11	0,14	0,17	0,19	0,23	0,27	0,30	0,36

Notes: For optimum performance when designing a system, calculate total friction loss to ensure sufficient downstream pressure.
 For optimum regulation performance, size regulating valves toward the higher flow ranges.
 Flow rates are recommended not to exceed 0,3 bar loss. Values shown in bar.

P220G Series Friction Loss Data*—(U.S.)

Size	Configuration	GPM Flow																
		5	10	20	30	40	50	60	70	80	90	100	110	120	130	140	150	180
25mm (1")	Globe	4,00	4,20	3,20	4,10	7,20												
	Angle	4,00	4,20	3,10	2,70	4,80												
40mm (1.5")	Globe				1,60	2,30	3,60	5,20	7,00	9,20	11,20	13,60	16,40					
	Angle				1,30	1,60	2,80	4,00	5,50	7,10	8,90	10,90	13,50					
50mm (2")	Globe									2,10	2,70	3,30	4,00	4,80	5,60	6,50	7,50	8,70
	Angle									1,20	1,60	2,00	2,40	2,80	3,30	3,90	4,40	5,20

Notes: For optimum performance when designing a system, be sure to calculate total friction loss to ensure sufficient downstream pressure.
 For optimum regulation performance, size regulating valves toward the higher flow ranges.
 Flow rates are recommended not to exceed 5 psi loss. Values shown in psi.

P220G AND P220GS SERIES VALVES

ACT™ System

Patent-pending Active Cleansing Technology – in which the turbine is constantly rotating to clean the metering/filtration area. This ensures that dirt, algae, chlorines, chloramines and water treated with ozone will not impede valve performance (P220GS only).

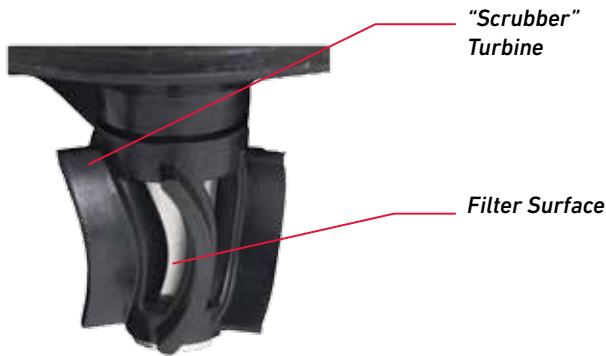

P220GS Scrubber Valve Series Friction Loss Data*—(Metric)

Size	Configuration	GPM Flow															
		5	10	20	30	40	50	60	70	80	90	100	110	120	130	140	150
1"	Globe	0,32	0,33	0,21	0,42	0,74											
	Angle	0,29	0,32	0,18	0,38	0,65											
1½"	Globe			0,08	0,11	0,20	0,30	0,43	0,59	0,77	0,97	1,19	1,41				
	Angle			0,07	0,10	0,16	0,25	0,36	0,48	0,64	0,81	1,01	1,20				
2"	Globe									0,25	0,32	0,37	0,47	0,57	0,62	0,72	0,80
	Angle									0,19	0,24	0,30	0,39	0,44	0,51	0,61	0,65

Note: For optimum performance when designing a system, be sure to calculate total friction loss to ensure sufficient downstream pressure.
For optimum regulation performance, size regulating valves toward the higher flow ranges.
Flow rates are recommended not to exceed 0,3 bar loss. Values shown in bar.

P220GS Scrubber Valve Series Friction Loss Data*—(U.S.)

Size	Configuration	GPM Flow															
		5	10	20	30	40	50	60	70	80	90	100	110	120	130	140	150
1"	Globe	4,63	4,74	3,10	6,05	10,75											
	Angle	4,14	4,64	2,54	5,53	9,46											
1½"	Globe			1,14	1,56	2,85	4,36	6,28	8,57	11,20	14,03	17,20	20,46				
	Angle			0,95	1,51	2,28	3,69	5,29	6,97	9,26	11,80	14,60	17,40				
2"	Globe									3,57	4,62	5,33	6,80	8,20	9,02	10,46	11,61
	Angle									2,79	3,50	4,41	5,62	6,39	7,35	8,81	9,37

Note: For optimum performance when designing a system, be sure to calculate total friction loss to ensure sufficient downstream pressure.
For optimum regulation performance, size regulating valves toward the higher flow ranges.
Flow rates are recommended not to exceed 5 psi loss. Values shown in psi.

Specifying Information—P220G and P220GS Series

P220GX-XX-OXYY			
Type	Body Style	Size	Optional
P220GX	XX	X	YY
P220G—P220G Series Plastic Valve P220GS—P220GS Plastic Scrubber Valve	27—NPT, Pressure-regulated 0,3-6,9 bar (5-100 PSI) 24—BSP, Pressure Regulated 0,3-6,9 bar (5-100 PSI)	4—25mm (1") 6—40mm (1.5") 8—50mm (2")	DL—DC Latching Solenoid

Example: A 25mm (1") P220G Series plastic electric, pressure-regulating valve with a 60 Hz solenoid, would be specified as: P220G-27-04

toro.com

Worldwide Headquarters
The Toro Company
8111 Lyndale Ave. So.
Bloomington, MN 55420 U.S.A.
Phone: (1) 952 888 8801
Fax: (1) 952 887 8258

Printed in U.S.A.
©2016 The Toro Company.
All Rights Reserved.
GB 200-XXXXNA Electronic file only.



facebook.com
twitter.com/TheToroCompany
youtube.com/ToroCompanyEurope



Count on it.