

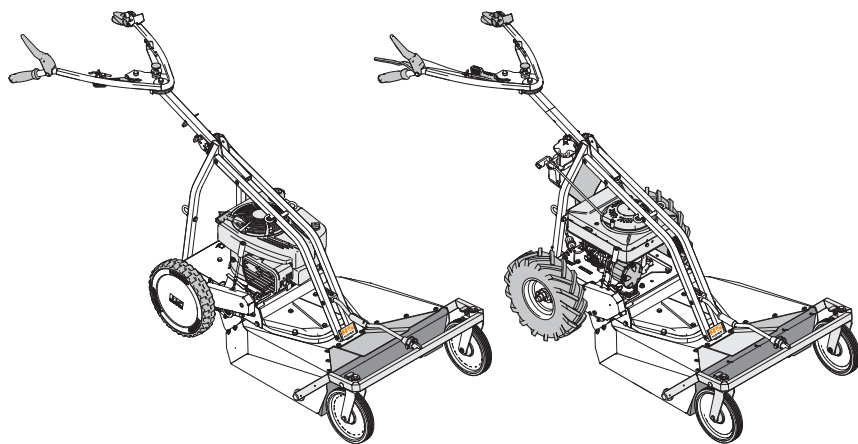

Operator's Manual



Allmäher®

AS 62 4T B&S, AS 63 2T ES, AS 63 4T B&S,
AS 63 4T Honda

From serial number: AS 62 4T B&S: 036019110001, AS 63 2T ES: 034619070001,
AS 63 4T B&S: 026917110001, AS 63 4T Honda: 027517110001

Issued: 26 November 2019, V6.0

en-Translation of the Original Operator's Manual

Notes on the operating manual

Dear customer,

Congratulations on your purchase. You have acquired a reliable quality product by "AS-Motor Germany".

This product has been manufactured according to modern manufacturing methods and comprehensive quality assurance measures. Only when you are satisfied with your device have we attained our goal.

These operating instructions contain important information to help you avoid hazards and to increase the reliability and the life span of the device.



Read the operating instructions before using the device. Share these operating instructions and the operating instructions of the engine with other users of the device.

Contact

If you have questions about your device, please contact your customer service.

For international AS partners, please see: www.as-motor.de.

Device data

Please fill in all data referring to your device. When ordering spare parts, provide your dealer with the serial and engine numbers.

Serial number (see manufacturer's certificate or type plate):

Engine number:

Date of purchase:

Address of dealer:

Intended use

The device is intended only for cutting grass or similar vegetation in well-maintained grounds in agriculture, forestry and preservation of the countryside that are cut at least once a year. Woody growth must not be older than maximally one year.

Only use attachments and cutting tools authorised by "AS-Motor Germany".

Any other use exceeding this purpose is inadmissible.

Observe the instructions chapter for Maintenance. Otherwise, operational safety is endangered.

The user of the device is responsible for accidents or damage that can happen to other persons or their property.

The device **must not** be used:

- To cut hard objects, rocks, rubble, or pieces of wood.
- To trim bushes, hedges, and shrubbery.
- To cut plants in flower pots or planters or on rooftops.
- To clean (vacuum) footpaths.
- As shredder for shredding tree and hedge cuttings.
- As drive unit for work tools and any type of tool sets that are not authorised by "AS-Motor Germany".

Contents

Notes on the operating manual	2	Starting	23
Contact	2	Starting the device (2-stroke device).....	23
Device data	2	Starting the device (4-stroke device without choke).....	23
Intended use	2	Starting the device (4-stroke device with choke).....	23
Explanation of the symbols	5	Engaging the blade.....	23
Symbols in the instructions.....	5	Driving AS 62 4T B&S	24
Warnings.....	5	Driving.....	24
Signs on the device.....	5	Turning.....	24
Type overview	7	Pushing.....	24
Safety instructions	8	Driving AS 63 2T ES, AS 63 4T B&S, AS 63 4T Honda	25
Get informed!.....	8	Driving.....	25
User restrictions and hours of operation..	8	Turning.....	25
Safe handling of fuel.....	8	Pushing.....	25
Check the device prior to use.....	9	Switching off and parking (4 stroke devices)	26
Danger area.....	9	Switching off and parking (2 stroke devices)	26
Use caution during operation.....	10	Transport	26
Prior to mowing.....	10	Transport position 1.....	26
Use caution when mowing.....	11	Transport position 2.....	27
Driving on slopes.....	12	Loading.....	28
When work is completed.....	12	Unloading the device.....	28
Use caution during maintenance and repair.....	13	Maintenance	29
Device description AS 62 4T B&S	14	Maintenance overview.....	30
Device description AS 63 2T ES, AS 63 4T B&S, AS 63 4T Honda	15	Cleaning position.....	32
Control elements	16	Cleaning the device.....	32
Operating elements only for 2-stroke devices.....	18	General inspection.....	32
Information on mowing	19	Transmission.....	33
Prior to starting	19	Checking the drive.....	33
Fuel used (2-stroke devices).....	19	Checking the parking brake.....	33
Fuel used (4-stroke devices).....	20	Grease lubrication.....	33
Check engine oil level (4-stroke devices).....	20	Checking the blade.....	34
Tanking up.....	20	Checking the blade clutch.....	34
Adjusting cutting height.....	21	Maintenance specifically for 2-stroke device	35
Locking steerable front wheel.....	22	Maintaining the engine.....	35
		Checking the spark plugs.....	35
		Maintaining the air filter.....	35

Maintenance specifically for 4-stroke device..... 36

- Maintaining the engine..... 36
- Checking the engine oil level..... 36
- Checking the spark plugs..... 36
- Maintaining the air filter..... 36

Assembly..... 37

- Scope of delivery..... 37
- Unpacking..... 37
- Unfolding the device..... 37

Storage..... 38

- Storing the device..... 38
- Longer storage..... 38
- Restarting..... 38

Spare parts..... 38

Wear parts..... 38

Disposal..... 38

Warranty..... 38

Troubleshooting..... 39

Fuel ratios of fuel 2-stroke devices..... 42

Technical data AS 63 2T ES..... 43

Technical data 4-stroke devices..... 44

Accessories..... 46

Declaration of conformity..... 47

Explanation of the symbols

Symbols in the instructions

In these operating instructions, the following symbols are used to denote special dangers.



Warning.
These symbols denote special dangers.



Prohibition sign.
These symbols denote inadmissible procedures.



Directive sign.
These symbols denote required protective measures.

Symbols in the text

1. A numbered text requests you to act or shows a process sequence.
 - ⇒ An indented arrow marks the result of a step.
 - ⇒ An arrow that is not indented refers to the result of a sequence of actions.

Notice: An additional piece of information is marked by the work "Notice" written in bold letters.

Warnings

In these operating instructions, warning instructions are marked with signal words. The signal words are used to indicate the following hazards and potential consequences.

Danger

Imminent danger

Indicates an imminently hazardous situation with a **high level of risk** that, if not avoided, **will** result in minor or moderate injury.

Warning

Hazardous situation

Indicates a possibly hazardous situation with a **medium level of risk** that, if not avoided, **could** result in minor or moderate injury.

Caution

Hazardous situation

Indicates a possibly hazardous situation with a **low level of risk** that, if not avoided, **could** result in minor or moderate injury.

Notice

Danger of property damage

Indicates a possible risk of damage of the device and its surroundings.

Signs on the device

The following signs are attached to the device to provide a reminder that during use of the device, you will have to be careful and attentive:



Working with the device requires extreme cautiousness.
Read the operating instructions before you use the device.



Risk of injury!
Make sure that no one is within the danger zone of the device.
Objects may be ejected.



The quickly rotating blade can cause life threatening injuries or immense property damage! Be especially careful to keep your hands and feet away from the blade when the device is put into operation.

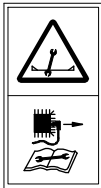

Prior to any repair and maintenance work, pull off the spark plug connector.



Clean the ventilation grid!
The cooling air of the motor is sucked in through the ventilation grid of the engine cover. Always keep the entire surface open and free!



Noise is causing health problems. Use personal ear protection to avoid hearing damage.



Hot surface. Do not touch the engine or the silencer. They become very hot during operation and you can get burned.



Do not clean the device with water spray or high-pressure cleaner!

Type plate

The type plate on the device provides you with information on the device type and the technical data.

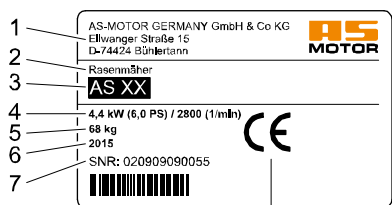

- 1 Name and address of the manufacturer
- 2 Device designation
- 3 Type designation
- 4 Rates power output in kW / engine speed
- 5 Weight
- 6 Year of manufacture
- 7 Serial number
- 8 CE marking

Type overview

In this operating manual, the following device types are described.

Depending on their equipment, the corresponding descriptions of this operating manual apply.

Equipment	AS 62 4T B&S	AS 63 2T ES	AS 63 4T B&S	AS 63 4T Honda
Accelerator lever without choke	X	X	X	-
Accelerator lever with choke	-	-	-	X
Choke and tickler	-	X	-	-
Number of fuel valves	1	1	1	2

Safety instructions

Get informed!

For your safety, read these operating instructions carefully. Familiarize yourself with the control elements and the proper use of the device. Share these operating instructions with other users of the device.

Have skilled personnel who were trained by AS-Motor show you the safe handling of the device before you work with it for the first time.

Get familiar with the device in a wide, open and flat terrain first.

User restrictions and hours of operation

Never allow children or persons who are not familiar with the operating instructions to use the device. Persons under 18 years of age may operate the device only under proper supervision. Local regulations determine the minimum age of the operator and the operating times.

Unsuitable for operation of the device are persons who

- are under the influence of alcohol, drugs or reaction retarding medicines.
- have physical and mental/emotional impairments.
- are tired or sick.



People fitted with pace makers are not allowed to touch any current carrying parts of the ignition system.

Safe handling of fuel

Fuel is toxic and highly flammable. There is a burn and explosion hazard!

Keep fuel away from ignition sources and do not smoke during handling.

Do not inhale fuel vapours, they are dangerous to your health.

Use gloves and avoid skin contact with the fuel.

Always refuel outdoors when the engine is cold and stopped completely. When doing so, always use a filler spout or a funnel.

Do not spill any fuel or do not let fuel enter canalisation or drain away.

When fuel has overflowed, do not start the device until the fuel vapours have evaporated (wipe dry). Move the device away from the spilled fuel.

Always close the tank cap tightly and do not open it while the engine is running or the device is still hot.

Empty the fuel only when outdoors. Use the approved container for this or run the fuel tank empty.

Store the fuel away from children and keep it in a suitable container in a dark, cool and dry place.

Never store the device when there is fuel in the tank inside a building where fuel vapours might come into contact with open fire or sparks.

Immediately replace the fuel tank or tank cap if they are damaged (authorised service centre).

First aid

When swallowing fuel or inhaling fuel vapours, do not force vomiting and immediately consult a doctor.

In case of skin contact, immediately wash with water and soap. Change your soiled clothing as soon as you can.

Measures in case of a fire

In case of a fire, use foam, dry powder extinguisher, or carbon dioxide (CO₂). Never douse with water!

Check the device prior to use

Prior to use, check the blade, protection skirt, drive and fastening parts, cables and cable connections for proper working condition and firm seating by visual inspection.

Never use the device with defective or missing covers or protection skirt or protection bow.

Do not remove, change or override any safety devices or control elements.

Observe the maintenance instructions (see chapter Maintenance).

Have an authorised service centre check your device if the blade does not stop within 7 seconds.

Danger area

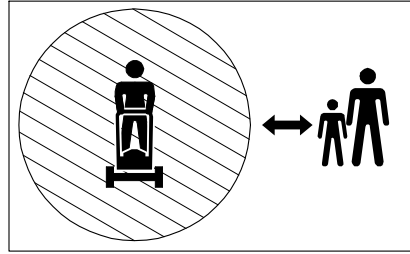

Within the danger area of the device, there is a risk of injury.

The rotating knife can cause injuries and objects can be thrown out. The area in front of and to the right of the device is especially dangerous.

On slopes, the device can topple over and slide towards persons or run them over.

Make sure

- that nobody else besides the user is on the mowing area.
- that people are never positioned in the direction of travel in front of the device.
- that nobody is positioned on the slope below the device.
- that you have a complete overview of the danger area at all times.
- that you keep your hands and feet away from the rotating parts.

Use caution during operation

Danger of injury during motor start

Do not start the engine

- if fuel was spilled.
- in closed or poorly ventilated rooms (danger of poisoning!).
- if there are other persons nearby.

Start the device only when your feet are at a safe distance to the blade.

Start the device only when the starter rope is fixed to the guide.

When the engine is started, do not tilt the device.

Risk of injury when the blade is running

Switch off the blade and wait until the blade stops

- when you drive on surfaces other than grass.

Risk of injury when the motor is running

Switch off the engine and wait until the blade stops

- before you tilt or transport the device.
- before you step away from the device, even for just a short time.
- before you adjust the cutting height.
- before you refuel.

Switch off the engine and wait until the blade comes to a standstill, and pull off the spark plug connector

- before you clean or check the device or before you carry out work on the device.
- before you unblock or unclog the discharge area.

Risk of burns

Do not touch the engine or the silencer. These parts become very hot during operation and you can get burned. If a jumpy movement occurs, the risk of additional injuries can result.

Prior to mowing

Personal protective measures



During mowing, always wear safety shoes with good grip and long trousers. Do not mow with open sandals or while shoeless.



Wear safety gloves to protect yourself against injuries and vibrations.



Noise is causing health problems. Use personal ear protection to avoid hearing damage. Wear safety glasses and headgear.

Ask your specialised dealer about suitable protective equipment.

Preparing the mowing area

Prior to mowing, carefully check the perimeter of the lawn. Remove rocks, pieces of wood, bones, wires, and other objects that could be picked up and thrown out by the device.

Remove live cables from the mowing area. These can be damaged during mowing and cause an electric shock or short circuit.

Use caution when mowing

Risk of injury

Risk of injury caused by ejected objects. Never mow when persons, children, pets or material assets are in the danger area.

Keep your hands and feet away from the rotating parts. Keep a distance to the ejection area while working with the device.

Make sure that help can be provided in case of an emergency.

Only mow during daylight or with adequate artificial lighting. Never mow in the event of uncertain weather conditions and risk of lightning.

Be especially carefully when mowing on soft ground, nearby landfills, ditches, dikes and water edges.

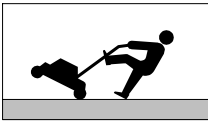

Avoid mowing damp grass, there is a sliding risk!

Be extremely cautious when turning the device round or pulling it toward you and when moving in reverse.

Always walk slowly!

Never lift or carry the device when the engine is running.

Pay attention to traffic when working close to roads.

Vibrations

When the device is used over a longer period of time, vibrations can cause disturbances in the blood supply of the hands. A generally accepted usage time cannot be determined.

- Use gloves.
- Take breaks on time.

Have an authorised service centre check the device

- when the blade has hit an object.
- if the device starts to vibrate unusually severely.

Mowing surfaces with fire hazard

- Carry a sufficient amount of suitable extinguishing agent.
- If side inclination is too great, fuel may leak from the carburetor or the tank. This poses a fire hazard!
- Observe the mowed surface also after moving is completed to ensure that no fire will start.

To avoid risk of fire, keep the following components free of dirt, grass, hay, leaking oil, grease, etc.:

- Engine
- Silencer (manifold, guard, clearances)
- Area around the fuel tank

Driving on slopes



Risk of injury during mowing on slopes due to tipping over or sliding.

- Mow on steep terrain only when safe operation can be guaranteed.
- Do not mow excessively steep slopes.
- Take suitable precautions on steep slopes, e.g. by using step irons.
- Always mow crossways to the slope, never upwards or downwards.
- Always make sure that you step safely, use non-slip safety shoes.
- Be extremely cautious when changing the direction.
- Mow only when the ground is dry and has a good grip.
- Mow only when the steerable front wheel is locked.

When facing downhill, the device can roll away. Park the device on level ground only and secure it against rolling away.

Devices fitted with a four stroke engines may only be operated on less than 20° slopes. Otherwise, the four stroke engine can be damaged due to insufficient oil lubrication.

If the device tilts or slips

- Never try to stop a tilting or sliding device. Severe injuries can result.
- Remove leaking fluids (oil, fuel, battery acid) from the device and the floor. Deposit of contaminated soil environment friendly according to the local regulation.
- Undetectable damage may have occurred to the device. In case of malfunctions, there is a risk of injury. Have an authorised service centre check the device.

When work is completed

After mowing, always close the fuel valve and the tank ventilation.

Prior to leaving the device, wait until the engine comes to a standstill and pull off the spark plug connector.

After switching it off, let the device cool down for at least 20 minutes before you store it in a dry, closed, sufficiently ventilated room.

Never store the device when there is fuel in the tank inside a building where fuel vapours might come into contact with open fire or sparks.

Use caution during maintenance and repair

Only carry out work as described in these operating instructions. Have an authorised service centre perform all other work.

Only use the blades and spare parts authorised by "AS-Motor Germany". Unauthorised blades and spare parts can cause severe injuries.

Prior to all maintenance work, wait until the engine comes to a standstill and pull off the spark plug connector.

We explicitly point out that, in accordance with the Product Liability Act, we are not liable for damages that were caused by our devices if

- worn or damaged parts were not repaired or replaced on time.
- these damages were caused by improper repair.
- when changing a part, our original parts or parts authorised by us were not used.
- the repair work was not carried out by an authorised service station.

The same applies for spare parts and accessories.

Device description AS 62 4T B&S

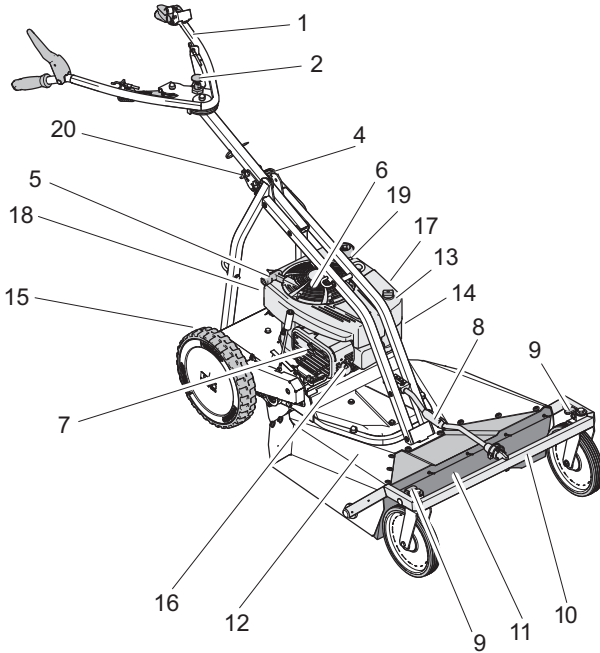

- | | |
|---|---|
| 1 Handlebar with control elements | 11 Protection skirt |
| 2 Lever for lateral adjustment of handlebar | 12 Cover |
| 3 (not existing) | 13 Air filter |
| 4 Accelerator lever with engine stop | 14 Carburetor |
| 5 Starter grip | 15 Cutting height adjustment rear |
| 6 Ventilation grid | 16 Spark plug connector |
| 7 Silencer | 17 Fuel valve |
| 8 Cutting height adjustment front | 18 Type plate |
| 9 Interlock steerable front wheel | 19 Tank filler spout |
| 10 Protection bow | 20 Lever for height adjustment of handlebar |

Device description AS 63 2T ES, AS 63 4T B&S, AS 63 4T Honda

The illustration shows AS 63 2T ES

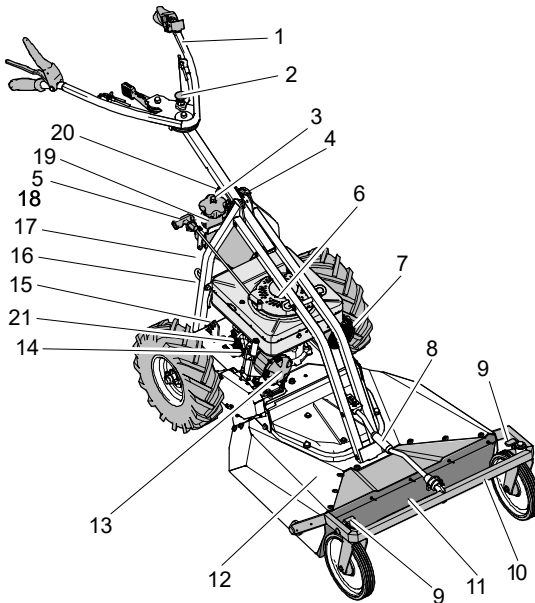

- | | | | |
|----|--|----|--|
| 1 | Handlebar with control elements | 11 | Protection skirt |
| 2 | Lever for lateral adjustment of handlebar | 12 | Cover |
| 3 | Tank ventilation | 13 | Air filter |
| 4 | Accelerator lever / accelerator lever with engine stop | 14 | Carburetor |
| 5 | Starter grip | 15 | Cutting height adjustment rear |
| 6 | Ventilation grid | 16 | Spark plug connector |
| 7 | Silencer | 17 | Fuel valve |
| 8 | Cutting height adjustment front | 18 | Type plate |
| 9 | Interlock steerable front wheel | 19 | Tank filler spout |
| 10 | Protection bow | 20 | Lever for height adjustment of handlebar |
| | | 21 | Engine stop switch |

Control elements

Handlebar with controls (1)

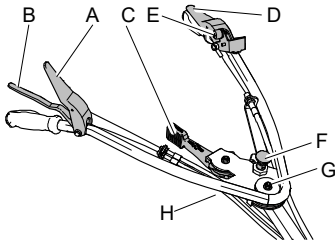

Drive lever (A)

AS 62 4T B&S

With the drive lever, you switch the drive on and off.

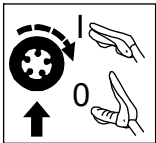

Drive on (I):

Press the lever towards the handlebar and continue to hold.

Drive off (0):

Release the lever.

Drive lever (A) and brake (B)

AS 63 2T ES, AS 63 4T B&S, AS 63 4T Honda

With the drive lever, you switch the drive and the parking brake on and off.



Drive off/ parking brake on (0):

Release the lever (A).

Drive on/ parking brake off (I):

Press the lever (A) towards the handlebar and continue to hold. A

Release brake:

Press brake lever (B) towards the handlebar. B

Vario lever (C)

With the vario lever, you can continuously adjust the speed of the device while the engine is running.

MIN: slow

MAX: fast

Blade clutch lever (D)

The engine clutch lever is a guard device.

When you release the lever, the blade comes to a standstill within 7 seconds.

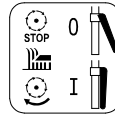

Disengaging blade (0):

Release the blade clutch lever and set the accelerator lever to MIN.

Engaging blade (I):

Lift the blade clutch lever, engage latch knob (E) and press blade clutch lever towards the handlebar.

accelerator lever with engine stop (4)

AS 62 4T B&S, AS 63 4T B&S, AS 63 4T Honda

With the accelerator lever, you can change the engine speed and thus control the engine output.

For devices with choke, set the accelerator lever to "Choke" when you start the cold engine. At the lowest position "0", the ignition is switched off and the engine is turned off.

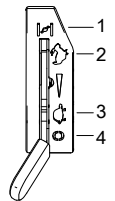

- 1: Choke = Choke closed (only device with choke)
- 2 Full throttle
- 3 Idle speed
- 4 Engine off

Accelerator lever (4)

AS 63 2T ES

With the accelerator lever, you can change the engine speed and thus control the engine output.

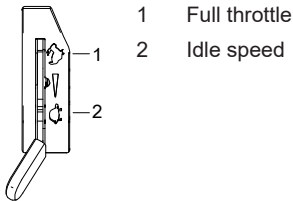

Lever for lateral adjustment of handlebar (2/F)

The handlebar can be fixed in 3 positions.

1. Pull the stop bolt (F) out of the notch (H).
2. Beware: Do not squeeze the Bowden cables when swivelling the handlebar. Swivel the handlebar to the side to the desired position. Let the stop bolt (F) engage in one of the three notches (H) at the guide bar.

Beware: A loose handlebar fastening can result in failure of the screwed connection. Always firmly tighten the central handlebar fastening (G).

Lever for height adjustment of handlebar (20)

The height of the handlebar can be set to 5 positions.

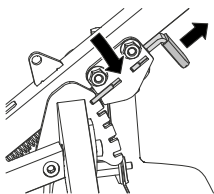

1. Pull the lever out of the notch.
2. Move the handlebar to the desired position.
3. Let the lever engage in one of the 5 notches.

Fuel valve (17)

AS 62 4T B&S

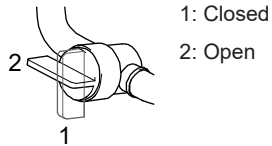

Fuel valve (17)

AS 63 2T ES, AS 63 4T B&S, AS 63 4T Honda

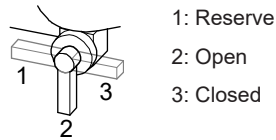

Second fuel valve (at the carburetor)

The second fuel valve must always be open. The fuel supply is regulated with the fuel valve at the tank.

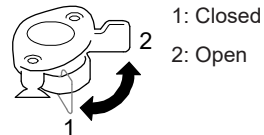

Operating elements only for 2-stroke devices

Carburetor (14) with choke and tickler

For cold start of the engine, you need the choke (1) and the tickler (2).

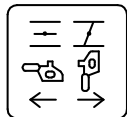

Open choke:

Turn clockwise to the stop.

Close choke:

Turn anti-clockwise to the stop.

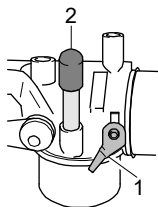

Fill carburetor with fuel:

Briefly press the tickler until fuel spills out.

Engine stop switch (21)

With the engine stop switch, you switch the ignition off or on. When you switch off the ignition, the engine is shut off.



0: OFF

I: ON

Information on mowing

Prior to mowing, check your device for completeness, proper functioning, and cleanliness. A dirty ventilation grid causes overheating of the engine, this can damage the engine. A dirty protective grid on the silencer poses a fire hazard.

Frequent engagement and disengagement of the clutch increases wear of the blade drive belt and the blade brake. Especially in case of high grass, clutch engagement leads to overload.

To keep the area well maintained, mow frequently and keep the grass short.

Only mow with a sharp and undamaged blade. Have the blade sharpened and balanced regularly (by authorised service centre).

Do not mow when the grass is wet or when it is raining. The turf may be damaged and there is a danger of slipping!

Turn the device around only in already mown sections. Do not leave the device unattended while the engine is running.

For mowing, always turn the accelerator lever to full throttle to achieve the best mowing performance.

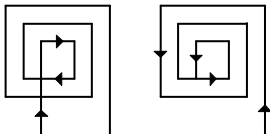

To avoid blockage during the ejection of grass, we recommend, for flat terrain, to proceed according to the mowing patterns. Mulch is shredded into much smaller pieces when you mow the terrain once again in the opposite direction.

If the grass is extremely high, mow twice at different cutting height settings.

Prior to starting

Fuel used (2-stroke devices)

The engine must be run on a mixture of petrol and two-stroke oil.

For possible mixing ratios, see chapter Mixing ratios fuel.

Use unleaded petrol (octane rating at least ROZ 91). You can use E10 petrol. Do not store E10 petrol longer than 30 days. Do not use fuels with more than 10 % ethanol (e.g. E15, E85).

Only use fully synthetic two-stroke oil intended for mixing in ratio 1:50. Do not use any mineral two-stroke oil.

AS-Motor recommendation:

Fully synthetic two-stroke oil **TITAN 2T 100S** in ratio **1:100**.

Your benefits:

- **Halve oil consumption compared to 1:50** - therefore more environmentally and cost friendly.
- Optimum protection of the engine for a long service life.
- Low engine wear.
- Maximum engine performance.

You can buy Fuchs "**TITAN 2T 100S**" of from your AS-dealer:

Container	ET no.
1 litre (resealable bottle)	G00041042
100 ml (disposable container)	G00041056
40 * 100 ml (disposable containers in box)	G00041058

Notice: You can find on the market ready mixed two-stroke fuels. Based on our experience, the ready mixed fuels “STIHL Motomix 1:50”, “ASPEN 2-stroke” and “Oest Oecomix” can be used. No guarantee can be given for operation of the device with other fuels and oils!

Do not use mixtures with more oil than 1:50 (e.g. 1:35).

Too much oil results in carbon deposits and reduces the service life of the engine.

Only use the fully synthetic two-stroke oils explicitly intended for mixing.

Use of engine oils or even waste oil results in engine damage.

No warranty is given in these cases.

Storing fuel mixture

The fuel mixture ages and can cause engine damages. Only mix as much fuel as you are going to use up during the next mowing.

Fuel used (4-stroke devices)

As fuel, use unleaded petrol (see operating instructions of the engine manufacturer).

You can use E10 petrol. Do not store E10 petrol longer than 30 days.

Check engine oil level (4-stroke devices)

Attention! Prior to each use, check the engine oil level (see operating instructions of the engine manufacturer).

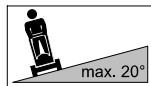

To ensure sufficient oil supply for the four stroke engine and to avoid resulting engine damage, the device may only be used on slopes up to 20°.

Tanking up

⚠ Warning

Fuel is ignited by hot engine parts.

- ▶ Prior to filling up, switch off the engine and wait for at least 20 minutes until the engine has cooled down. Observe the safety instructions regarding the fuel!

⚠ Warning

The fuel tank on the engine is not connected (only applies to AS 63 2T ES, AS 63 4T B&S, AS 63 4T Honda).

Filled fuel can run out and ignite.

- ▶ Never fill fuel into the tank on the engine.

Filling up with fuel

1. For filling, use a canister with filler spout or a funnel.
2. Open the canister carefully so that existing excess pressure is slowly reduced.
3. Open the tank cap carefully so that existing excess pressure is slowly reduced and no fuel sprays out.
4. Fill the fuel tank.
5. Tightly close the tank cap again.

Adjusting cutting height

Adjust the cutting height setting only when the engine is switched off.

Set the cutting height so that the blade does not touch the ground even in case of terrain unevenness. If the cutting height is set too high, objects can be ejected and the “clean cut appearance” can be destroyed.

The adjustment of the cutting height is performed per axle.

If the scale shows the same position for both axles, the blade is parallel to the mowing area.

Front axle

The cutting height adjustment of the front axle is infinitely variable.

1. Switch off the engine and wait until the engine comes to a standstill.

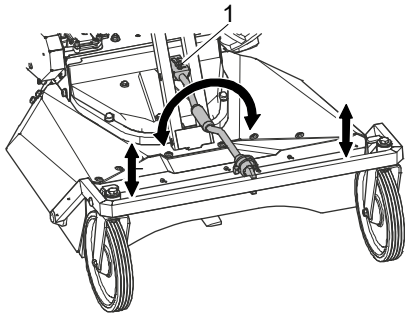

2. Turn the crank at the front axle until the desired cutting height was reached.
- ⇒ The lubricating nipple (1) shows the set position on the scale.

Rear axle

AS 62 4T B&S

The height on the rear axle can be adjusted to 5 positions.

1. Switch off the engine and wait until the engine comes to a standstill.

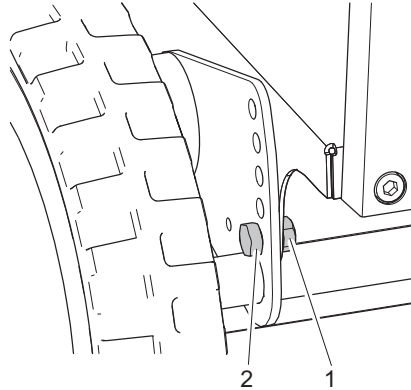

2. Slacken the nuts (1) and remove the screws (2).
3. Lift the device to the desired height.
4. Insert the screws (2) into the hole from the outside.
5. Tighten the nuts (1) on the screws (2).

Rear axle

AS 63 2T ES, AS 63 4T B&S, AS 63 4T Honda

The height on the rear axle can be adjusted to 4 positions.

1. Switch off the engine and wait until the engine comes to a standstill.

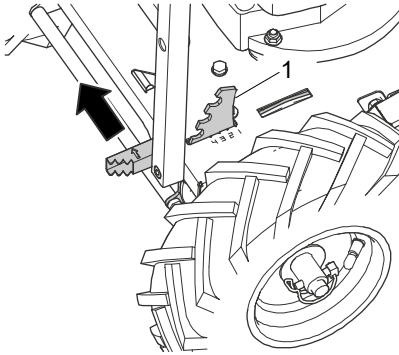

2. Push the lever on the rear axle to the left using your foot.
 3. Lift the device to the desired height.
 4. Release the lever and let it engage in the desired height.
- ⇒ The edge (1) shows the set position on the scale.

Locking steerable front wheel

It is more comfortable on an even surface to let the front wheels swivel. If you move crossways to the slope, make sure the wheels are locked.

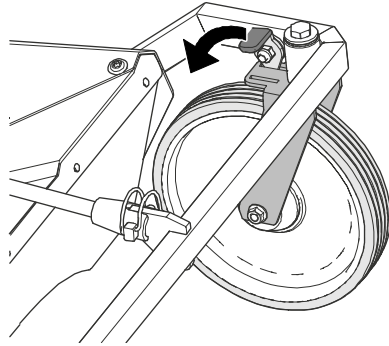

Releasing the steerable front wheel

1. Turn the lever out of the guide.

Interlocking the steerable front wheel

1. Position the steerable front wheel straight in direction of travel.
2. Screw the lever into the guide.

Starting

Warning

During startup, there is a risk of injury caused by the rotating blade.

- ▶ Make sure that no one is within the danger zone of the blade. Do not tip the device over to one side during startup.

Warning

Danger of poisoning due to poisonous exhaust gases.

- ▶ Do not operate the engine in closed or insufficiently ventilated rooms.
- ▶ Please observe the safety instruction regarding the poisoning risk.

Warning

If after startup the carburetor does not close properly, fuel will overflow and a fire hazard occurs.

- ▶ Close the fuel valve and contact an authorised service centre.

Starting the device (2-stroke device)

1. Place the device onto a flat surface, not in high grass.
2. Open the fuel valve and the tank ventilation.
3. Plug on the spark plug connector.
4. Only for cold start: Close the choke at the carburetor (turn anti-clockwise).
5. Press the tickler at the carburetor until the fuel is seen to drip.
6. Set the engine stop switch to "I".
7. Put the accelerator lever to lowest engine speed position.
8. Pull the starter point slowly out until you feel resistance then pull out quickly – engine starts to run.
9. Let the starter rope retract slowly.
10. Put the accelerator lever to medium engine speed position.

11. Reopen the choke (turn clockwise).
12. For mowing, set the accelerator lever to the maximum speed.

Starting the device (4-stroke device without choke)

1. Place the device on even terrain and not in high grass.
2. Open the fuel valve and the tank ventilation (if existing).
3. Plug in the plug connector.
4. Turn the accelerator lever to "idle speed".
5. Pull the starter rope slowly out until you feel resistance and then pull out quickly – engine starts to run.
6. Slowly release the starter rope.
7. For mowing, set the accelerator lever to the maximum speed.

Starting the device (4-stroke device with choke)

1. Place the device on even terrain and not in high grass.
2. Open the two fuel valves and the tank ventilation.
3. Plug in the plug connector.
4. Set the accelerator lever during cold start to the position "Choke", otherwise to medium speed.
5. Pull the starter rope slowly out until you feel resistance and then pull out quickly – engine starts to run.
6. Slowly release the starter rope.
7. For mowing, set the accelerator lever to the maximum speed.

Engaging the blade

1. Lift the blade clutch lever.
2. Press the latch knob at the blade clutch lever.
3. Press the blade clutch lever towards the handlebar – the blade starts to move.

Disengaging the blade when moving over paths:

1. Release the blade clutch lever.

Driving AS 62 4T B&S

Warning

Risk of injury caused by tripping or sliding while pushing the mower, moving it backwards and turning it round.

- ▶ Make sure that the area is clear of objects and watch for safe footing.

Driving

Warning

When facing downhill, the device can roll away.

- ▶ Only drive on slopes on which you can stop the device.

In case of a hazardous situation, switch off the drive and declutch the blade.

Drive on

1. Press the drive lever towards the handlebar – device is running.

Drive off:

1. Release the drive lever.

Adjusting speed

With the vario lever, you can continuously adjust the speed of the device.

Only adjust the driving speed when the engine is running; otherwise, the vario drive can be damaged.

Turning

Turn the device round only where the grass has been mowed already.

Turning round on an even surface:

1. Switch off the drive.
2. Turn the device to the desired side.
3. Switch the drive back on.

Turning round on a sloping area:

1. Keep the drive switched on.
2. Turn the device upslope.
3. Hold back the handlebar and the inner wheel.

The drive prevents sliding and supports the turn manoeuvre.

Pushing

Release the drive lever.

The device can be pushed.

Driving AS 63 2T ES, AS 63 4T B&S, AS 63 4T Honda

Warning

Risk of injury caused by tripping or sliding while pushing the mower, moving it backwards and turning it round.

- ▶ Make sure that the area is clear of objects and watch for safe footing.

Driving

In case of a hazardous situation, switch off the drive and declutch the blade.

Drive on

1. Press the drive lever towards the handlebar – device is running.

Drive off:

1. Release the drive lever.

Driving down slope

When driving down slope, continue to have the drive switched on to keep the driving speed constant.

Adjusting speed

With the vario lever, you can continuously adjust the speed of the device.

Only adjust the driving speed when the engine is running; otherwise, the vario drive can be damaged.

Turning

Turn the device around only in already mown sections.

Turning on a level surface:

1. Switch off the drive.
2. Press the brake lever towards the handlebar to release the brake.
3. Swivel the device to the desired side.
4. Switch the drive back on.

Turning on the slope:

1. Keep the drive switched on.
2. Turn the device uphill.
3. Hold back the handlebar and the inside wheel.

The drive prevents sliding and supports the turning process.

Pushing

1. Release the drive lever.
2. Press the brake lever towards the handlebar to release the brake.

Switching off and parking (4 stroke devices)

Warning

On a slope, the device can roll away.

- ▶ Put the device on even ground only or secure it against rolling away.

1. Release the drive lever.
2. Turn the accelerator lever to "0".
3. Release the blade brake clutch lever.
4. Wait for the engine to stop completely before you step away from the device.
5. Close the fuel valve and the tank ventilation (if existing).
6. Pull off the plug connector.

Switching off and parking (2 stroke devices)

Warning

On a slope, the device can roll away.

- ▶ Put the device on even ground only or secure it against rolling away.

1. Release the drive lever.
2. Set the accelerator lever to the lowest engine speed.
3. Release the blade clutch lever.
4. Set the engine stop switch to "0".
5. Wait until the engine comes to a standstill before you step away from the device.
6. Close the fuel valve and the tank ventilation.
7. Pull off the spark plug connector.

Transport

Warning

Risk of injury due to the heavy weight of the device. The device can fall over and fall down and cause severe injuries.

- ▶ Observe the following notices.

Transport the device by truck or trailer designed for a payload of at least the empty weight of the device.

Prior to each transport, let the device cool down for at least 20 minutes.

Beware: Do not store or transport the device in cleaning position.

Fuel and oil can leak and soil or damage the device and the ground.

Transport position 1

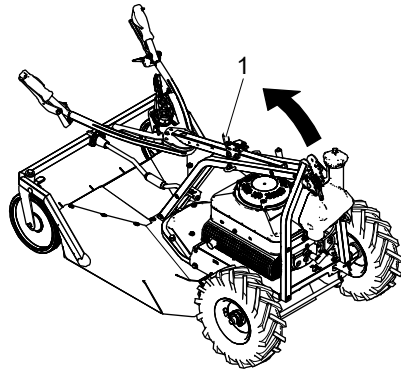

1. Pull the lever (1) out of the notch for the lever for handelbar height adjustment and flip the guide bar to the front.

Transport position 2

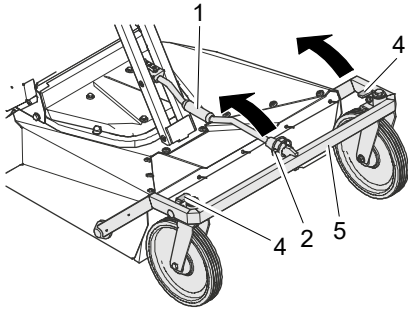

1. Release the interlock of the steerable front wheel (4) at both front wheels.
2. Pull off the spring cotter (2) at the crank (1) for height adjustment.
3. Completely flip up the crank (1) for the height adjustment.
4. Completely flip up the protective bow (5).
5. Lock the steerable front wheels (4).

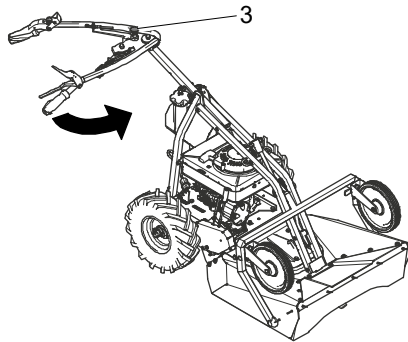

6. Pull the stop bolt (3) for the lever for the lateral adjustment out of the notch.
7. **Beware:** Do not squeeze the Bowden cables when swivelling the handlebar. Swivel the handlebar anti-clockwise all the way to the stop.

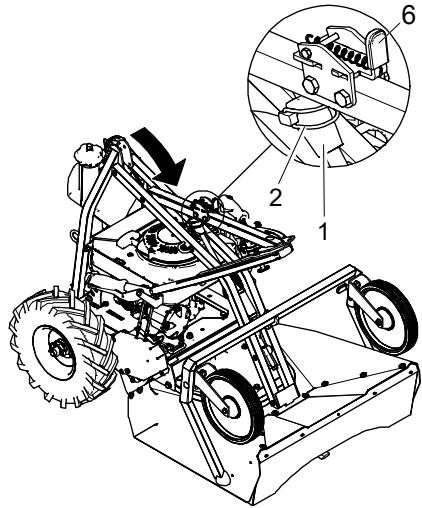

8. Pull the lever (6) out of the notch for the lever for handlebar height adjustment and flip the guide bar to the front.
9. Lock the crank (1) for the height adjustment with a spring cotter (2) at the guide bar.

Loading

Use suitable ramps for loading that

- can carry the empty weight of the device + 200 kg.
- are wider than the device.
- have a slip-free surface.

Notice

Risk of damage due to incorrect fastening of straps.

- ▶ Fasten the straps only at the points shown in the figure.
 - ▶ Do not overtighten the straps.
1. Put the device in front of the ramps and make sure that the ramps
 - are as wide as the wheel gauge of the device.
 - are tightly secured to the platform.
 - are not steeper than 15°.
 2. Carefully drive the device via the ramps onto the platform.
 3. Observe the instructions in chapter Switching off and parking.
 4. Secure the device against rolling, sliding and tilting. Use straps that support the weight of the device.
 5. Secure the device with belts to the frame elements that can hold the weight.

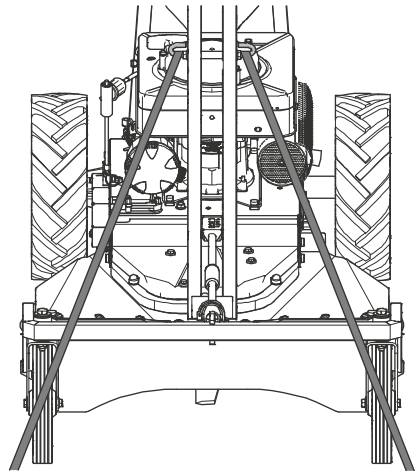
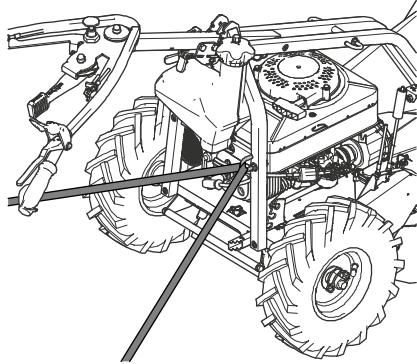

Unloading the device

1. Undo the transport fastenings.
2. Drive the device carefully down the ramps of the platform.

Maintenance

Warning

Risk of injury due to unexpected movement. When inspections are carried out, the device can move unexpectedly.

- ▶ Make sure that no persons or objects are in the danger area of the blade.
- ▶ Make sure that no further hazards result from an unexpected movement.

Warning

Risk of injury during maintenance and cleaning work when the engine is running.

- ▶ Perform maintenance tasks only then with a running engine if this is required in the Maintenance table.

Warning

Danger of poisoning due to poisonous exhaust gases.

- ▶ Do not operate the engine in closed or insufficiently ventilated rooms.
- ▶ Please observe the safety instruction regarding the poisoning risk.

Prior to all maintenance and cleaning work when the engine is not running:

1. Let the device cool down for at least 20 minutes.
2. Pull off the plug connector.
3. Close the fuel valve and the tank ventilation.

Improper maintenance can make the device unsafe for operation and result in accidents. Regular maintenance keeps your device ready for use.

Service the device according to the following maintenance instructions.

Contact an authorised service centre if problems during maintenance occur or if you determine deficiencies during one of the following inspections.

Maintenance overview

Component	Action	Maintenance interval	
		A	B
Device	Check for safe working condition (basic inspection).	■	▲
	Clean.	■	
	Customer service.		▲
Fuel	Check fuel level.	■	
	Is the tank cap closed?	■	
Tank, fuel valve, and fuel line	Check parts for leaks and check for good condition.	■	▲
Carburetor	Does the carburetor close again after starting?	■	▲
Ventilation grid	Clean.	■	▲
Engine cooling	Clean.		▲
Spark plug	Check/replace.		▲
Air filter	Maintain.	■	■▲
Blade and fastening components	Check for wear and damage. See chapter Checking the blade.	■	▲
	Change.		▲
Blade brake clutch	Does the blade function safely and does the blade stop in 7 seconds?	□	▲
Release the drive lever	Does the device stop when the lever is in zero position?	□	▲
Drive	Check.	■	▲
V-belt	Are the belts tensioned correctly, without fissures, and in good condition?		▲
Bowden cables	Check for proper function and ease of movement.	■	▲
Acceleration lever	Check for proper function.	□	▲
Chassis and impact protection	Check for rust and fissures and check the welding seams.	■	▲
	Are all protective devices and covers in place, fastened correctly and properly functioning?	■	▲
Label	Condition of the labels.	■	▲
Parking brake	Check.	■	▲

Flammable material	Remove easily flammable debris buildup from the engine and the device.	■	▲
Tyres	Check tyres and, if necessary, the tyre pressure.	■	▲
Lubrication	See chapter grease lubrication.	■	▲ ■

For 4-stroke devices:

Engine	For reliable information, see the operating manual of the engine manufacturer.	■	▲
	Check oil level (see operator's manual of the engine manufacturer).	■	▲
	Oil change.		▲

- A Before and after each use.
- B Annually or every 50 h.
- By the user when the engine is not running.
- By the user when the engine is running.
- ▲ By the authorised service centre.

Cleaning position

AS 62 4T B&S

For work on the bottom side of the device, flip the device to the silencer side.

AS 63 2T ES, AS 63 4T B&S, AS 63 4T Honda

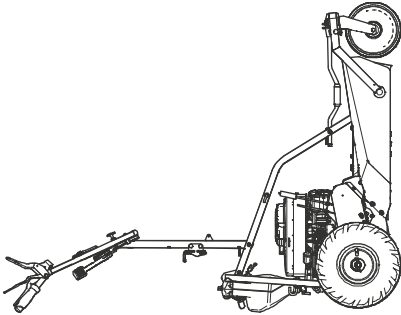

Caution

Risk of injury.
Guide bar can snap back.

► To provide secure stand, place the guide bar onto the ground.

1. Pull the lever of the height adjustment for handelbar out of the notch and flip the guide bar to the front (do not crush the Bowden cables).
2. Flip the device to the rear as shown in the figure.
3. Place the guide bar on the floor.

Beware: Do not tilt the device towards the air filter side because then the engine oil can enter the air filter and thus render the filter useless.

Cleaning the device

Depending on use, clean the device thoroughly, especially the bottom and the blade.

Grass cuttings and dirt that are stuck interfere with the grass ejection and impair the cutting quality. To sufficiently cool the engine, keep the engine cover, ventilation grid and engine clean.

Fire hazard! Take particular care that the components at the silencer are clean.

For cleaning, use a hand brush. Remove stubborn dirt with a wooden or plastic spatula. Clean the outside housing parts with a cloth.

Do not clean the device with water spray or high-pressure cleaner! Do not use any aggressive cleaning agents.

General inspection

To make sure that the device can be operated safely, check all nuts, bolts, screws, rubber elements, air filters, connections of fuel lines, etc. regularly for proper condition and firm seating. Check the ignition wire and the spark plug connector for damage.

Immediately replace damaged or worn parts, especially covers, silencers or fuel tank (authorised service centre).

Check all parts that contain fluids for leaks and proper condition. These can be: Fuel tank, fuel valve, fuel lines, carburetor, engine, gears, battery, hydraulic system.

In case of leaks, contact an authorised service centre.

Transmission

The transmission is maintenance-free and filled with oil that is supposed to last the entire service life of the device. Make sure that there are no leaks or damages.

Checking the drive

1. Put the device on a non-slip surface (e.g. concrete or asphalt).
2. Switch off the engine.
3. Actuate the drive.
4. Try to pull the device backwards.

If the rear wheels lock, the drive is correctly adjusted. If you can pull the device, the drive must be re-adjusted.

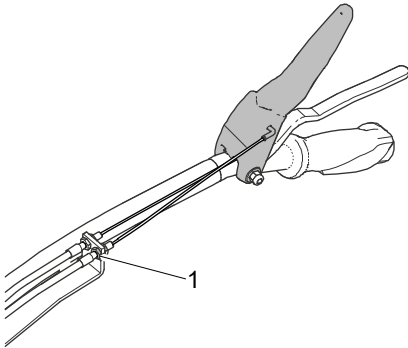

Re-adjusting the drive

Turn the adjusting screw (1) at the drive so that the wheels lock, while the drive is actuated, when the device is pulled. If there is no improvement after the adjustment, have the device checked by an authorised service centre.

Checking the parking brake

AS 63 2T ES, AS 63 4T B&S, AS 63 4T Honda

Warning

If the parking brake is incorrectly adjusted, the device can roll away.

- ▶ Make sure that the parking brake is always functioning properly.

1. Place the device on a surface with a good grip (e.g. concrete or asphalt).
2. Release the drive lever and the brake lever.
 - ⇒ Parking brake is actuated.
3. Try to pull the device backwards.

If the rear wheels lock up, the parking brake is set correctly. If the device can be pushed, the parking brake must be readjusted by an authorised service centre.

Grease lubrication

The cutting height setting at the front axle is shown by a lubricating nipple.

1. Clean the lubricating nipple.
2. Lubricate the lubricating nipple with a grease gun (1-2 strokes).
3. Remove excess grease that has been pressed out of the bearing points.

Checking the blade

Warning

Wear or damage on the blades and the fastening elements can result in the blades or the fastening elements coming off.

- ▶ Check the blades and all fastening elements according to the following instructions.

Warning

There is a considerable risk of injury due to improperly mounted and maintained blades.

- ▶ Work at blades must be carried out by an authorised service centre.



Use solid gloves when you check the blade.

Work on the blade requires specific expertise because an imbalance inspection is necessary and torques must be observed.

Blades that are sharpened improperly increase the workload of the device and can result in vibration cracks or breaks.

Check the blade and all fastening elements for wear, damage and cracks

- each time before and after you mow.
- in case of noticeable changes or unusual vibrations.

Contact an authorised service centre if you detect faults or damage during inspection.

All shown blade parts and their fastening elements must be changed

- if damage or cracks are detected.
- if unusually strong vibrations occur.
- at least once a year or every 50 operating hours, no matter if wear does exist or not.

The material weakens, can suffer cracks, endangering people and material assets. Ejected broken pieces can cause severe injuries.

Unusual vibrations are an indication that

- blades are missing or broken,
- the blade is worn excessively or on one side or
- damage to the engine or cutter deck fastening.

Blade change

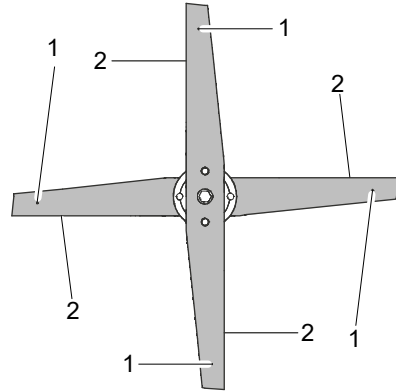

It is absolutely necessary to change the blade:

- When one of the wear markings (1) was reached. Original blades are engraved with wear markings (marking in form of a ball-shaped imprint on the rear side of the blade).
- When the thickness of the blade at the rear edge of the vane (2) or at another point is below 1 mm (exception: cutting edge).

Original blade

An original AS-blade is engraved with:

AS XXXXXXXX

The engraving shows the spare part number.

Checking the blade clutch

Check the blade clutch for proper function by disengaging the blade. The blade must come from full speed to a standstill in less than 7 seconds. Contact an authorised service centre if this is not the case.

Maintenance specifically for 2-stroke device

Maintaining the engine

Warning

If the speed of rotation is set too high, objects can be ejected. The engine can be damaged and noise pollution increases.

- ▶ Do not change the basic setting of the carburetor or the speed control.

To ensure a long service life of the engine, sufficient engine cooling is required.

Keep the

- engine cover (ventilation grid),
 - silencer (protective grid) and
 - cooling fins of the engine
- clean at all times.

Checking the spark plugs

Danger

The ignition system generates an electro-magnetic field.

- ▶ Wearers of pacemakers must not work on live parts.

Soiled spark plugs reduce the engine output. Clean the electrode of the spark plug with a brass wire brush. Check the electrode gap (see "Technical data"). Make sure that the insulator around the electrode is not damaged. Never use a damaged spark plug.

Tighten the spark plug with the torque indicated in the technical data.

Maintaining the air filter

Warning

Cleaning agents pose a fire and explosion hazard.

- ▶ Never clean the air filter with flammable solvents.

Notice

A cleaning of the air filter with compressed air damages the filter fabric and the air filter becomes useless.

- ▶ Change the air filter when it is dirty.

Notice

When you use air filters from accessory suppliers, the engine can be damaged.

- ▶ Only use the original AS-Motor air filter cartridges.

Beware! During filter change, accumulated dirt in the air filter can get into the carburetor and damage it.

1. Screw off the air filter cap.
2. Carefully pull out the filter element. Make sure that no dirt from the inside of the air filter housing enters the carburetor.
3. Close the suction opening with a clean cloth.
4. Thoroughly clean the inside of the air filter housing.
5. Remove rough, loose dirt from the filter element by tapping. Replace the filter element in case of heavy, stubborn dirt.
6. Remove the cloth of the suction opening.
7. Re-insert the filter element.
8. Close the air filter cap again.

Maintenance specifically for 4-stroke device

Maintaining the engine

Caution

If the speed is set too high, objects can be ejected. The engine can be damaged and a higher level of noise pollution is produced.

- ▶ Do not change the basic setting of the carburetor or the speed control.

The engine manufacturer has prepared the operating manual of the engine. The manual contains all maintenance requirements and warranty conditions for the engine. If warranty work on the engine is required, contact your authorised service centre or the next authorised dealer for engines.

To ensure a long service life of the engine, sufficient engine cooling is required.

Keep the

- engine cover (ventilation grid),
 - silencer (protective grid) and
 - cooling fins of the engine
- clean at all times.

Checking the engine oil level

Never allow the oil level to be too low otherwise the engine can be damaged. Never fill in too much oil. Otherwise, there is the risk that the oil enters and destroys the air filter.

For this, observe the attached operating instructions of the engine.

Checking the spark plugs

Danger

The ignition system generates an electromagnetic field.

- ▶ Wearers of pacemakers must not work on live parts.

Soiled spark plugs reduce the engine output. Clean the electrode of the spark plug with a brass wire brush. Check the electrode gap (see operating instructions of the engine manufacturer). Make sure that the insulator around the electrode is not damaged. Never use a damaged spark plug.

Tighten the spark plug using the correct torque (see operating instructions of the engine manufacturer).

Maintaining the air filter

Warning

There is a fire and explosion risk due to cleaning agents.

- ▶ Never clean the air filter with flammable solvents.

Make sure that the air filter is always clean. A dirty air filter reduces the engine power and leads to increased engine wear and fuel consumption. Independent of the operating hours, change the filter insert at least once a year. Do not operate the engine without air filter.

For this, observe the attached operating instructions of the engine.

Assembly

Scope of delivery

The device is shipped in a carton.

The scope of delivery included:

- The device.
- Tool bag.
- This operating manual.
- Manufacturer's certificate.
- Operating instructions of engine manufacturer (4-stroke devices).

Unpacking

1. Open the box at the top.
2. Remove all loose parts from the box.
3. Cut open the front side of the box.
4. Fold up the handlebar (see Unfolding the device).
5. Check the air pressure of the tyres (see Technical data).
6. Press the brake bar towards the handlebar to release the brake and push the device out of the box.

Unfolding the device

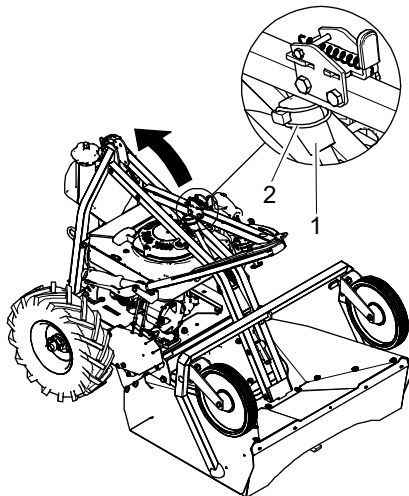

1. Pull off the spring cotter (2) between the guide bar and crank of the height adjustment (1) starting from.
2. Unfold the guide bar until it engages.

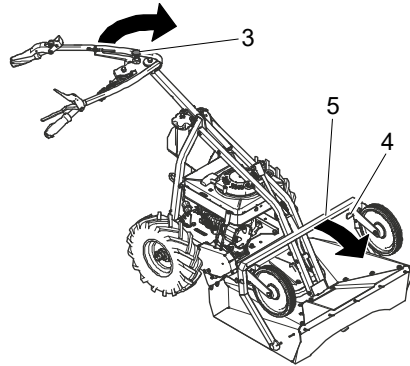

3. Pull the stop bolt (3) for the lever for the lateral adjustment out of the notch.
4. **Beware:** Do not squeeze the Bowden cables when swivelling the handlebar. Swivel the handlebar clockwise to the desired position. Let the stop bolt engage in one of the three notches of the guide bar.
5. Release the interlock of the steerable front wheel (4) at both front wheels.
6. Flip down the protective bow (5).

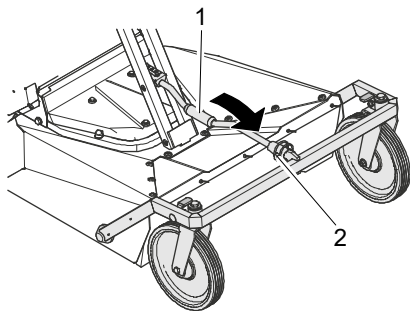

7. Flip the crank of the height adjustment (1) to the front.
8. Lock the crank of the height adjustment with the spring cotter (2) at the protection bow.

Storage

Beware: Do not store or transport the device in cleaning position.

Fuel and oil can leak and soil or damage the device and the ground.

Storing the device

Keep the device in a closed, dry, and well ventilated room and out of reach of children. Always eliminate all problems of the device before you store it so that the device is always in a safe-to-operate state. Let the engine cool down before you store the device in closed rooms.

Also observe the notices on storage in the attached operating instructions by the engine manufacturer.

Longer storage

1. Observe the safety instructions for handling the fuel.
2. Emptying fuel tank. Place a piece of hose onto the fuel valve and let the fuel run into an approved fuel container.
3. Emptying carburetor: Start the engine and let it run until it stops by itself.
4. Thoroughly clean the device.
5. Touch up any possible damage to the paint finish (for paint, see Accessories).

Before longer storage, e.g. in the fall, have an authorised service centre check the device!

Also observe the notices on storage in the attached operating instructions by the engine manufacturer.

Restarting

If you want to start the device after a longer storage, carry out the tasks described in chapter Maintenance.

Spare parts

The reliable and safe operation of the device also depends on the quality of the spare parts used. Only use original spare parts and accessories that were approved by "AS-Motor Germany". When foreign parts are installed, the warranty and guarantee shall be void for the foreign part and for the device and for any resulting damage.

Inform your authorised service centre about the device type and serial number of your devices when you order spare parts.

Wear parts

Some parts are wear parts. They wear during use and must be replaced. The warranty does not cover the following parts:

Blades, cutting blades, cutter bars, blade bolts, sliding plates, V-belt, chains, Bowden cables, starter ropes, pressure plates, air filters, spark plugs, disc springs, lock washers, fuses, discs, thrust plates, pressure discs, protection skirts, impact protection, wheels, tires.

Disposal

The device cuts and shreds the plant material in a single operation. Shredded plant material decomposes quickly, can be utilized as fertilizer, and, therefore, be left on the ground.

Dispose of waste oil and fuel in accordance with the local regulations or return it to an oil shop.

Packaging, device, and accessories are made of recyclable materials and must be disposed of accordingly.

Warranty

Please see our AS-Motor website for warranty information.

Please print out the documents that you receive during the online registration. Keep them together with your sales receipt.

Troubleshooting

The following table contains the most frequent problems and their elimination. If more problems occur, contact the closest authorised service centre.

You can find an authorised service centre on our home page www.as-motor.de.

Problem	Possible cause	Remedy
Engine does not start	Accelerator lever to "0".	Turn the accelerator lever to "idle speed".
	Fuel valve is closed.	Open fuel valve. For devices with two fuel valves, open both.
	Tank ventilation screw is closed.	Open tank ventilation screw.
	No fuel is in the tank.	Refill fuel.
	Choke is open.	Close the choke.
	Spark plug connector is pulled off.	Observe the safety instructions! Put spark plug connector back on.
	Engine was flooded due to too many start attempts.	Unscrew spark plug and start several times when the fuel valve is closed, dry the spark plug and screw it back in.
	Air filter is dirty.	Maintain air filter (see Maintenance).
	Spark plug is dirty, damaged, or incorrect electrode gap.	Clean spark plug and check electrode gap (see Maintenance). Replace spark plug if necessary.
	Wrong spark plug connector.	Use the specified spark plug connector (see spare part information of the authorised service centre).
	Poor quality, dirty, or old fuel.	Clean fuel system (authorised service centre). Always use fresh fuel.

Engine starts badly or runs irregularly	Choke is closed.	Open the choke.
	Air filter is dirty.	Maintain air filter (see Maintenance).
	Poor quality, dirty, or old fuel.	Always use fresh fuel.
	Spark plug is dirty, damaged, or incorrect electrode gap.	Clean spark plug and check electrode gap (see Maintenance). Replace spark plug if necessary.
	Wrong spark plug connector.	Use the specified spark plug connector (see spare part information of the authorised service centre).
	Decompression bore is blocked.	Authorised service centre.
No drive when drive lever is actuated	Drive belt is insufficiently tensioned.	See also Checking the drive.
The blade does not rotate	V-belt is insufficiently tensioned or damaged.	Authorised service centre.
	Bowden cable is defective.	Authorised service centre.
Strong vibrations during operation	Imbalance of the blade caused by incorrect sharpening or chips on the blade.	Have blade resharpened and balanced by an authorised service centre. Replace a damaged blade immediately.
	Blade drive shaft is bent due to collisions with foreign objects.	Authorised service centre.
	Engine fastening is loose.	Authorised service centre.
	Blade fastening is loose.	Authorised service centre.
Irregular noises	Loose fastening elements.	Authorised service centre.
	Silencer is defective.	Authorised service centre.
Engine gets hot	Ventilation grid is dirty.	Clean ventilation grid.
	Cooling fins of the engine are dirty.	Have cooling fins cleaned by authorised service centre.
Engine is smoking	Air filter is dirty or drenched with oil.	Maintain or replace air filter (see chapter Maintenance).
	Oil level is too high.	Have authorised service centre lower the oil level to the marking.

Uneven cut, lawn becomes unsightly	Blade is dull or worn.	Have blade resharpened and balanced by an authorised service centre. Replace a damaged blade immediately.
	Speed is too high proportionately to the cutting height.	Reduce speed and/or select the correct cutting height.
	Housing of the mower is heavily contaminated.	Clean.
	Different tire pressure.	Check the tire pressure.
Mulching result with high plant material not satisfactory	Speed is too high.	Reduce speed.
Mulching result with low plant material not satisfactory	Plant material is ejected too quickly.	Increase speed.
Discharge channel is jammed	Mowed grass was too long or too damp.	Adjust cutting height and mowing speed to the mowing conditions.
	Blade is worn.	Authorised service centre.
	Engine speed is too low despite full power.	Authorised service centre.
The device does not stop when the brake is applied (if existing)	Brake is adjusted incorrectly, worn, or defective.	Check the parking brake (see chapter Maintenance). Authorised service centre.
The device does not stop	Drive belt does not declutch.	Authorised service centre.
The engine does not switch off	Switching off system is defective.	Close the fuel valve. Authorised service centre.
The tires become flat	Thorns or sharp objects damage the tires.	If necessary, use tire protection gel (authorised service centre).

Fuel ratios of fuel 2-stroke devices

Fuel	Fully synthetic two-stroke oil	Only with Titan 2T 100S
(octane rating ROZ 91 min.)	1:50	1:100
litres	Litre (=ml/cm ³)	Litre (=ml/cm ³)
1	0.02 (20)	0.01 (10)
2	0.04 (40)	0.02 (20)
3	0.06 (60)	0.03 (30)
4	0.08 (80)	0.04 (40)
5	0.1 (100)	0.05 (50)
10	0.2 (200)	0.1 (100)
20	0.4 (400)	0.2 (200)

Do not use mixtures with more oil than 1:50 (e.g. 1:35).

Too much oil results in carbon deposits and reduces the service life of the engine.

Only use the fully synthetic two-stroke oils explicitly intended for mixing. Do not use mineral two-stroke oil.

Use of engine oils or even waste oil results in engine damage.

No warranty is given in these cases.

Technical data AS 63 2T ES

Type	AS 63 2T ES
Range of application (temperature)	0 - 30 °C
Engine, type Manufacturer Type Cylinder capacity Performance Engine speed	One cylinder two-stroke engine with easy start AS-Motor Germany AS 165 ES (Easystart) 165 cm ³ 4,0 kW (5,4 PS) 3800 min ⁻¹
Spark plug Torque Electrode gap for optimal starting behaviour	NGK BR6HS 25 Nm 0.5 – 0.7 mm
Cutting device, type Cutting height	2 knives (cross knives) 50, 65, 80, 100 mm, per axis
Growth height	up to approx. 100 cm
Cutting width	61 cm
Starting device	Rope start
Traction drive	Rear wheel drive with Variomat for variable adjustment of the speed
Speed forward	2,0 - 4,0 km/h
Maximum area coverage	ca. 2400 m ² /h
Measures and weight Transport size with packaging L/W/H max. tyre dimensions L/W/H Weight	102/72/78 cm 191/70/99 cm 78 kg
Capacities Fuel tank	3 Liter
Sound level according to DIN EN 12733 Measured sound level L _{WA} Sound level at working place L _{pA} Measurement uncertainty k	102,2 dB 90,3 dB 3,0 dB (A)
Vibration emission value according to DIN EN 12733 Hand-arm-vibrations a _{h,W} Measurement uncertainty U	3,1 m/s ² 2,0 m/s ²
Tyre pressure rear	2,0 bar

Technical data 4-stroke devices

Type	AS 63 4T B&S	AS 63 4T Honda
Range of application (temperature)	0 - 30 °C	
Engine, type	One cylinder four stroke engine	One cylinder four stroke engine
Manufacturer	Briggs & Stratton	Honda
Type	Series 850, I/C	GXV 160
Cylinder capacity	190 cm ³	163 cm ³
Performance	3,7 kW (5,1 PS)	3,2 kW (4,3 PS)
Engine speed	3600 min ⁻¹	3600 min ⁻¹
Cutting device, type	2 knives (cross knives)	
Cutting height	50, 65, 80, 100 mm, per axis	
Growth height	up to approx. 90 cm	up to approx. 80 cm
Cutting width	61 cm	
Starting device	Rope start	
Traction drive	Rear wheel drive with Variomat for variable adjustment of the speed	
Speed forward	1,8 - 3,8 km/h	
Maximum area coverage	ca. 2300 m ² /h	
Measures and weight		
Transport size with packaging L/W/H	102/72/78 cm	102/72/78 cm
max. tyre dimensions L/W/H	191/70/99 cm	191/70/99 cm
Weight	74 kg	82 kg
Capacities		
Fuel tank	3 Liter	
Sound level		
according to DIN EN 12733		
Measured sound level L _{WA}	94,9 dB	96,1 dB
Sound level at working place L _{pA}	82,8 dB	87,3 dB
Measurement uncertainty k	3,0 dB(A)	3,0 dB(A)
Vibration emission value		
according to DIN EN 12733		
Hand-arm-vibrations a _{h,w}	3,0 m/s ²	2,7 m/s ²
Measurement uncertainty U	2,0 m/s ²	2,0 m/s ²
Tyre pressure rear	1,0 - 2,0 bar	

Type	AS 62 4T B&S
Range of application (temperature)	0 - 30 °C
Engine, type Manufacturer Type Cylinder capacity Performance Engine speed	One cylinder four stroke engine Briggs & Stratton Series 850, I/C 190 cm ³ 3,7 kW (5,1 PS) 3600 min ⁻¹
Cutting device, type Cutting height	2 knives (cross knives) 50, 65, 80, 100 mm, per axis
Growth height	up to approx. 90 cm
Cutting width	61 cm
Starting device	Rope start
Traction drive	Rear wheel drive with Variomat for variable adjustment of the speed
Speed forward	1,8 - 3,8 km/h
Maximum area coverage	ca. 2300 m ² /h
Measures and weight Transport size with packaging L/W/H max. tyre dimensions L/W/H Weight	102/72/78 cm 191/70/99 cm 66 kg
Capacities Fuel tank	1,2 Liter
Sound level according to DIN EN 12733 Measured sound level L _{WA} Sound level at working place L _{pA} Measurement uncertainty k	95,0 dB 84,2 dB 3,0 dB(A)
Vibration emission value according to DIN EN 12733 Hand-arm-vibrations a _{h,w} Measurement uncertainty U	4,2 m/s ² 2,0 m/s ²

Accessories

Spray paint 400 ml, colour orange:	G00011050
Operating hours counter:	G06927008
Clinometer:	G06950027
Mulching accessory:	G60026026

Only applies for AS 63 2T ES, AS 63 4T B&S, AS 63 4T Honda:

Twin tires:	G06321009
Flat tyre protection 950 ml:	G00041068
Flat tyre protection 20 l:	G00041069
Pump for flat tyre protection 20 l:	G00041070

Only applies for AS 63 2T ES:

Snorkel filter:	G60005003
-----------------	-----------

Declaration of conformity

We declare that the grassland mowers

Type	AS 62 4T B&S	AS 63 2T ES	AS 63 4T B&S	AS 63 4T Honda
starting from serial no.	036019110001	034619070001	026917110001	027517110001

as brought into circulation by us conform to all relevant safety and health requirements of the EC directives listed.

- 2006/42/EC
- 2014/30/EC

Function:

The device is intended only for cutting grass or similar vegetation in well-maintained grounds in agriculture, forestry and preservation of the countryside that are cut at least once a year.

Applied standards:

DIN EN 12733

Place where all technical records are filed:

AS-Motor Germany GmbH & Co. KG
Ellwanger Straße 15
D-74424 Bühlertann

Bühlertann, in November 2019



Eberhard Lange
Managing director



By proxy Frank Einsiedler
Head of development



AS-Motor Germany GmbH & Co. KG
Ellwanger Straße 15
D-74424 Bühlertann
www.as-motor.de



THE HIGH GRASS MOWER AND 2 STROKE ENGINE MANUFACTURE

AS-Motor is your premium manufacturer for lawn and high grass mowers as well as 2 stroke engines. We offer our customers professional technology for steep slopes, rough terrain, and lawn care. Our extensive product range which includes hand-held entry-level devices up to the world's first all-wheel ride-on mower with remote control will always offer private customers, municipalities service providers the right product. For more than 60 years, we have been developing and producing with a high production depth in Southern Germany and supply our dealer network in more than 30 countries all over the world.

- Mulching mower** Mulching mower – the time-saving alternative!
AS-Motor mulching mowers shred the grass to create such a fine mulch, almost an “invisible” fertiliser, that sinks right away back into the lawn. Disposal of the cuttings is not required.
- Professional lawn mower** Professional lawn mowers with rear or side discharge for every requirement, even with all-wheel drive, brake and reverse gear.
- Brush cutter®** An agile lawn mower for maintenance of extensive grassed areas. The Allmäher® reliably mows and mulches metre-high grass, brushes and weeds.
- Flail mower** High grass with undergrowth, steep slope or extensive areas in unknown terrain? The movably mounted flail blades of the AS-Motor flail mower give way to rocks and obstacles and chop the cuttings several times over.
- Ride-on brush cutter** If extensive areas, weeds and undergrowth up to 1.2 m, the AS-Motor all-wheel mowers are also perfect for steep and even extremely steep terrain. Ease of use and high area performance combined in one compact ride-on mower. For more safety, comfort and efficiency in difficult terrain we have developed the innovative and the world's first remote controlled ride-on mower.
- Rotary mower** The cost-effective alternative to the cutter-bar mower. Also ideal for feed production. The grass is not shredded but deposited in straight rows as a windrow next to the machine.
- Weed remover** Careful and chemical-free weed removal. The AS-Motor weed removers “WeedHex” mechanically clean paved areas and curb stones from growing weeds – quickly, safely, and efficiently.