

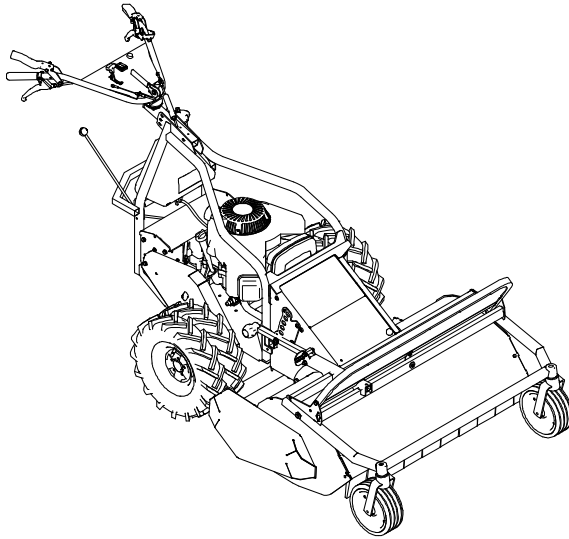

Operator's Manual



Flail Mower

AS 701 SM, AS 901 SM

From serial number: AS 701 SM: 026817110001, AS 901 SM: 026017110001

Issued: 27.10.2017, V4.0

en-Translation of the Original Operator's Manual

Notes on the operating manual

Dear customer,

Congratulations on your purchase. You have acquired a reliable quality product by "AS-Motor Germany".

This product has been manufactured according to modern manufacturing methods and comprehensive quality assurance measures. Only when you are satisfied with your device, we have attained our goal.

These operating instructions contain important information to help you avoid hazards and to increase the reliability and the life span of the device.



Read the operating instructions before using the device. Share these operating instructions and the operating instructions of the engine with other users of the device.

Contact

If you have questions concerning your device, please contact your dealer or call our customer service (+49 7973 9123-0).

For international AS partners, please see: www.as-motor.de.

Device data

Please fill in all data referring to your device. When ordering spare parts, provide your dealer with the serial and engine numbers.

Serial number (see manufacturer's certificate or type plate):

Engine number:

Date of purchase:

Address of dealer:

Intended use

The device is intended only for cutting grass or similar vegetation in well-maintained grounds in agriculture, forestry and preservation of the countryside that are cut at least once a year. Woody growth must not be older than maximally one year.

Only use attachments and cutting tools authorised by "AS-Motor Germany".

Any other use exceeding this purpose is inadmissible.

Observe the instructions chapter for Maintenance. Otherwise, operational safety is endangered.

The user of the device is responsible for accidents or damage that can happen to other persons or their property.

The device **must not** be used:

- To cut hard objects, rocks, rubble, or pieces of wood.
- To trim bushes, hedges, and shrubbery.
- To cut plants in flower pots or planters or on rooftops.
- To clean (vacuum) footpaths.
- As shredder for shredding tree and hedge cuttings.
- As drive unit for work tools and any type of tool sets that are not authorised by "AS-Motor Germany".

Contents

Notes on the operating manual	2	Transport	16
Contact	2	Loading.....	16
Device data	2	Unloading the device.....	17
Intended use	2	Maintenance	17
Explanation of the symbols	4	Maintenance overview.....	18
Symbols in the instructions.....	4	Cleaning the device.....	20
Symbols on the device.....	4	General inspection.....	20
Safety instructions	5	Chain lubrication.....	20
Get informed!.....	5	Transmission.....	20
User restrictions and hours of operation..	5	Maintaining the engine.....	21
Safe handling of fuel.....	5	Checking the engine oil level.....	21
Check the device prior to use.....	6	Checking the spark plug.....	21
Danger area.....	6	Maintaining the air filter.....	21
Use caution during operation.....	7	Checking the drive.....	22
Prior to mowing.....	7	Checking the parking brake.....	22
Use caution when mowing.....	7	Checking the blade.....	22
Caution when mowing slopes.....	8	Checking the blade clutch.....	24
When work is completed.....	9	Check oil level of the bevel gear.....	24
Use caution during maintenance and repair.....	9	Assembly	24
Device description	10	Scope of delivery.....	24
Control elements	11	Unpacking.....	24
Information on mowing	12	Guide bar and handlebar.....	24
Prior to starting	13	Storage	25
Fuel.....	13	Storing the device.....	25
Tanking up.....	13	Longer storage.....	25
Checking the engine oil level.....	13	Restarting.....	25
Adjusting cutting height.....	13	Spare parts	26
Starting	14	Wear parts	26
Starting the device (AS 901 SM).....	14	Disposal	26
Starting the device (AS 701 SM).....	14	Warranty	26
Engaging the blade.....	14	Troubleshooting	27
Oil pressure switch.....	14	Technical data	30
Driving	15	Accessories	31
Driving.....	15	Declaration of conformity	32
Reverse gear.....	15		
Steering and turning.....	15		
Pushing.....	15		
Switching off and parking	16		

Explanation of the symbols

Symbols in the instructions

In these operating instructions, the following symbols are used to denote special dangers.



Warning.
These symbols denote special dangers.



Prohibition sign.
These symbols denote inadmissible procedures.



Directive sign.
These symbols denote required protective measures.

Symbols on the device

The following symbols are placed on the device to inform you must be careful and attentive when using the device:



Working with the device requires extreme cautiousness.
Read the operating instructions before you use the device.



Risk of injury!
Make sure that no one is within the danger zone of the device.
Objects may be ejected.

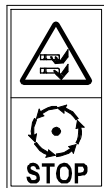

The quickly rotating blade can cause life threatening injuries or immense property damage! Be especially careful to keep your hands and feet away from the blade when the device is put into operation.

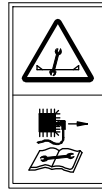

Prior to any repair and maintenance work, pull off the spark plug connector.



Clean the ventilation grid!
The cooling air of the motor is sucked in through the ventilation grid of the engine cover. Always keep the entire surface open and free!



Noise is causing health problems. Use personal ear protection to avoid hearing damage.



Do not clean the device with water spray or high-pressure cleaner!

Type plate

The type plate on the device provides you with information on the device type and the technical data.

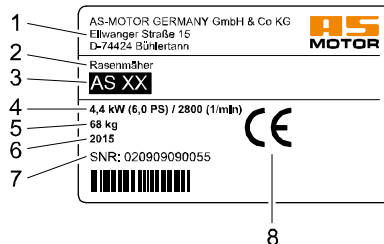

- 1 Name and address of the manufacturer
- 2 Device designation
- 3 Type designation
- 4 Rates power output in kW / engine speed
- 5 Weight
- 6 Year of manufacture
- 7 Serial number
- 8 CE marking

Safety instructions

Get informed!

For your safety, read these operating instructions carefully. Familiarize yourself with the control elements and the proper use of the device. Share these operating instructions with other users of the device.

Have skilled personnel who were trained by AS-Motor show you the safe handling of the device before you work with it for the first time.

Get familiar with the device in a wide, open and flat terrain first.

User restrictions and hours of operation

Never allow children or persons who are not familiar with the operating instructions to use the device. Persons under 18 years of age may operate the device only under proper supervision. Local regulations determine the minimum age of the operator and the operating times.

Unsuitable for operation of the device are persons who

- are under the influence of alcohol, drugs or reaction retarding medicines.
- have physical and mental/emotional impairments.
- are tired or sick.



People fitted with pace makers are not allowed to touch any current carrying parts of the ignition system.

Safe handling of fuel

Fuel is toxic and highly flammable. There is a burn and explosion hazard!

Keep fuel away from ignition sources and do not smoke during handling.

Do not inhale fuel vapours, they are dangerous to your health.



Use gloves and avoid skin contact with the fuel.

Always refuel outdoors when the engine is cold and standing still. When doing so, always use a filler spout or a funnel.

Do not spill any fuel or do not let fuel enter canalisation or drain away.

When fuel has overflowed, do not start the device until the fuel vapours have evaporated (wipe dry). Move the device away from the spilled fuel.

Always close the tank cap tightly and do not open it while the engine is running or the device is still hot.

Empty the fuel only when outdoors. Use the approved container for this or run the fuel tank empty.

Store the fuel away from children and keep it in a suitable container in a dark, cool and dry place.

Never store the device when there is fuel in the tank inside a building where fuel vapours might come into contact with open fire or sparks.

Immediately replace the fuel tank or tank cap if they are damaged (authorised service centre).

First aid

When swallowing fuel or inhaling fuel vapours, do not force vomiting and immediately consult a doctor.

In case of skin contact, immediately wash with water and soap. Change your soiled clothing as soon as you can.

Measures in case of a fire

In case of a fire, use foam, dry powder extinguisher, or carbon dioxide (CO₂). Never douse with water!

Check the device prior to use

Prior to use, check the blade, protection skirt, drive and fastening parts, cables and cable connections for proper working condition and firm seating by visual inspection.

Never use the device with defective or missing covers or protection skirt or protection bow.

Do not remove, change or override any safety devices or control elements.

Have an authorised service centre check your device if the blade does not stop within 7 seconds.

Observe the maintenance instructions (see Maintenance).

Danger area

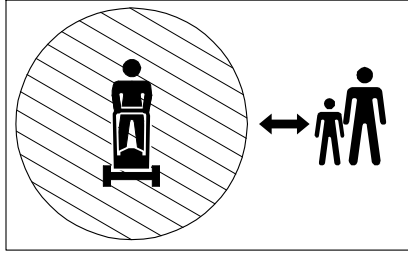

Within the danger area of the device, there is a risk of injury.

The rotating knife can cause injuries and objects can be thrown out. The area in front of and to the right of the device is especially dangerous.

On slopes, the device can topple over and slide towards persons or run them over.

Make sure

- that nobody else is in the area that will be mowed.
- that people are never positioned in the direction of travel in front of the device.
- that nobody is positioned on the slope below the device.
- that you have a complete overview of the danger area at all times.
- that you keep your hands and feet away from the rotating parts.

Use caution during operation

Danger of injury during motor start

Do not start the engine

- if fuel was spilled.
- in closed or poorly ventilated rooms (danger of poisoning!).
- if there are other persons nearby.

Start the device only when your feet are at a safe distance to the blade.

When the engine is started, do not tilt the device.

Risk of injury when the blade is running

Switch off the blade and wait until the blade stops

- when you drive on surfaces other than grass.

Risk of injury when the motor is running

Switch off the engine and wait until the blade stops

- before you tilt or transport the device.
- before you step away from the device, even for just a short time.
- before you adjust the cutting height.
- before you refuel.

Switch off the engine and wait until the blade comes to a standstill, and pull off the spark plug connector

- before you clean or check the device or before you carry out work on the device.
- before you unblock or unclog the discharge area.

Risk of burns

Do not touch the engine or the silencer. These parts become very hot during operation and you can get burned. If a jumpy movement occurs, the risk of additional injuries can result.

Prior to mowing

Personal protective measures



During mowing, always wear safety shoes with good grip and long trousers. Do not mow with open sandals or while shoeless.



Wear safety gloves to protect yourself against injuries and vibrations.



Noise is causing health problems. Use personal ear protection to avoid hearing damage. Wear safety glasses and headgear.

Ask your specialised dealer about suitable protective equipment.

Preparing the mowing area

Prior to mowing, carefully check the perimeter of the lawn. Remove rocks, pieces of wood, bones, wires, and other objects that could be picked up and thrown out by the device.

Use caution when mowing

Risk of injury

Risk of injury caused by ejected objects. Never mow when persons, children, pets or material assets are in the danger area.

Keep your hands and feet away from the rotating parts. Keep a distance to the ejection area while working with the device.

Make sure that help can be provided in case of an emergency.

Only mow during daylight or with adequate artificial lighting. Never mow in the event of uncertain weather conditions and risk of lightning.

Be especially carefully when mowing on soft ground, nearby landfills, ditches, dikes and water edges.

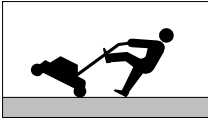

Avoid mowing damp grass, there is a sliding risk!

Be extremely cautious when turning the device round or pulling it toward you and when moving in reverse.

Always walk slowly!

Never lift or carry the device when the engine is running.

Pay attention to traffic when working close to roads.

Vibrations

When the device is used over a longer period of time, vibrations can cause disturbances in the blood supply of the hands. A generally accepted usage time cannot be determined.

- Use gloves.
- Take breaks on time.

Have an authorised service centre check the device

- when the blade has hit an object.
- if the device starts to vibrate unusually severely.

Mowing surfaces with fire hazard

- Carry a sufficient amount of suitable extinguishing agent.
- If side inclination is too great, fuel may leak from the carburetor or the tank. This poses a fire hazard!
- Observe the mowed surface also after moving is completed to ensure that no fire will start.

To avoid risk of fire, keep the following components free of dirt, grass, hay, leaking oil, grease, etc.:

- Engine
- Silencer (manifold, guard, clearances)
- Area around the fuel tank

Caution when mowing slopes



There is a risk of injury during driving on slopes due to tipping over or sliding.

- Drive on steep terrain only when safe operation can be guaranteed.
- Do not drive on excessively steep slopes.
- Take suitable precautions on steep slopes, e.g. by using step irons.
- Always drive crossways to the slope, never upwards or downwards.
- Always make sure that you step safely, use non-slip safety shoes.
- Be extremely cautious when changing the direction.
- Drive only when the ground is dry and has a good grip.
- When driving on the slope, make sure the steerable front wheel is locked.

When facing downhill, the device can roll away. Park the device on level ground only and secure it against rolling away.

Observe the information regarding the oil pressure switch in chapter Starting.

If the device tilts or slips

- Never try to stop a tilting or sliding device. Severe injuries can result.
- Remove leaking fluids (oil, fuel, battery acid) from the device and the floor. Deposit of contaminated soil environment friendly according to the local regulation.
- Undetectable damage may have occurred to the device. In case of malfunctions, there is a risk of injury. Have an authorised service centre check the device.

When work is completed

After mowing, always close the fuel valve.

Prior to leaving the device, wait until the engine comes to a standstill and pull off the spark plug connector.

After switching it off, let the device cool down for at least 20 minutes before you store it in a dry, closed, sufficiently ventilated room.

Never store the device when there is fuel in the tank inside a building where fuel vapours might come into contact with open fire or sparks.

Use caution during maintenance and repair

Only carry out work as described in these operating instructions. Have an authorised service centre perform all other work.

Only use the blades and spare parts authorised by "AS-Motor Germany". Unauthorised blades and spare parts can cause severe injuries.

Prior to all maintenance work, wait until the engine comes to a standstill and pull off the spark plug connector.

We explicitly point out that, in accordance with the Product Liability Act, we are not liable for damages that were caused by our devices if

- worn or damaged parts were not repaired or replaced on time.
- these damages were caused by improper repair.
- when changing a part, our original parts or parts authorised by us were not used.
- the repair work was not carried out by an authorised service station.

The same applies for spare parts and accessories.

Device description

The illustration shows AS 901 SM

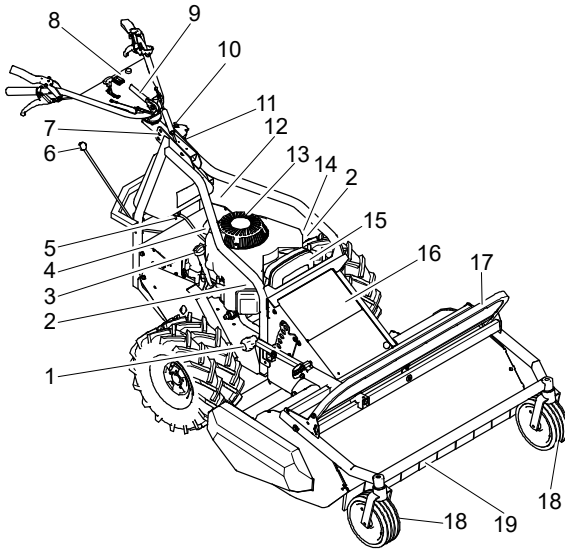

- 1 Cutting height adjustment
- 2 Spark plug connector
(bei AS 901 SM: 2 connectors)
- 3 Oil dipstick
- 4 Starter grip
- 5 Fuel valve
- 6 Switching lever
- 7 Height adjustment of handlebar
- 8 Handlebar console
- 9 Lever for lateral adjustment of
handlebar
- 10 Tank ventilation
- 11 Tank filler spout
- 12 Type plate
- 13 Ventilation grid
- 14 Choke (only AS 901 SM)
- 15 Air filter
- 16 Silencer
- 17 Protection bow
- 18 Steerable front wheel
- 19 Protective flaps

Control elements

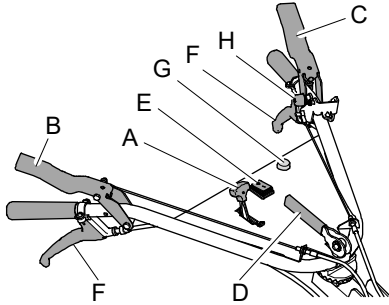

Throttle lever (A - AS 901 SM)

With the accelerator lever, you change the engine speed and thus control the engine output.



MAX: Full throttle

MIN: Neutral position

Accelerator lever with choke (A - AS 701 SM)

With the accelerator lever, you can change the engine speed and thus control the engine output.



Choke: Choke closed (only for engine start when engine is cold).

MIN: Idling

MAX: Full throttle

Drive lever and parking brake (B)

With the drive lever, you switch the drive and the parking brake on and off.

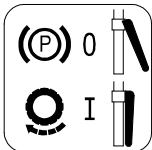

Drive off/ parking brake on (0):
Release the lever.

Drive on/ parking brake off (I):
Press the lever towards the handlebar and continue to hold.

Blade clutch lever (C)

The engine clutch lever is a guard device. When you release the lever, the blade comes to a standstill within 7 seconds.

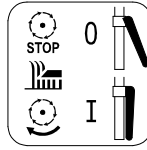

Uncouple blade (0):

Release the blade clutch lever and set the accelerator lever to MIN.

Couple blade (I):

Lift blade clutch lever, engage latch knob (H) and press the blade clutch lever towards the handlebar. H

Lever for lateral adjustment of handlebar (D)

1. Release the eccentric tension lever.
2. Attention: Do not crush the Bowden cables when pivoting the handlebar. Swivel the handlebar to the side to the desired position.
3. Clamp the handlebar with the eccentric tension lever.

Height adjustment of handlebar (7)

The height of the handlebar can be adjusted via the screw of the handlebar height adjustment (see Assembly).

Engine stop switch (E)

Switch the ignition on and off with the engine stop switch. When you switch off the ignition, the engine is switched off.

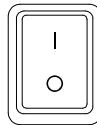

I: ON

O: OFF

Steering brake lever (F)

You control the driving direction of the device with both steering brake levers.

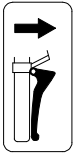

Swivelling to the right:
Press the right lever towards the handlebar.



Swivelling to the left:
Press the left lever towards the handlebar.

Start button (G)

Press and hold the start button during the starting procedure (see Starting).

Switching lever (6)

The transmission has 5 forward gears, idle and a reverse gear. For shifting, release the drive lever and shift to the next gear and start again.

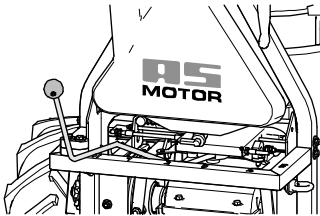

- R Reversing
- N Idle speed
- 1-5 Moving forward

Choke (14)

Close the choke during cold start of the engine.

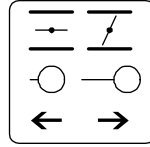

Opening choke:
Push wire ring inwards.

Closing choke:
Pull wire ring outwards.

Fuel valve (5)

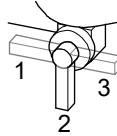

- 1: Reserve
- 2: Open
- 3: Closed

Information on mowing

Prior to mowing, check your device for completeness, proper functioning, and cleanliness. A dirty ventilation grid causes overheating of the engine, this can damage the engine. A dirty protective grid at the silencer poses a fire hazard.

Frequent engagement and disengagement of the clutch increases wear of the blade drive belt and the blade brake. Especially in case of high grass, clutch engagement leads to overload.

To keep the area well maintained, mow frequently and keep the grass short.

Only mow with a sharp and undamaged blade. Have the blade sharpened and balanced regularly (by authorised service centre).

Do not mow when the grass is wet or when it is raining. The turf may be damaged and there is a danger of slipping!

Turn the device around only in already mown sections. Do not leave the device unattended while the engine is running.

For mowing, always turn the accelerator lever to full throttle to achieve the best mowing performance.

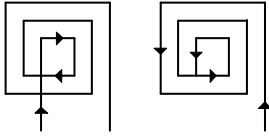

To avoid blockage during the ejection of grass, we recommend, for flat terrain, to proceed according to the mowing patterns. Mulch is shredded into much smaller pieces when you mow the terrain once again in the opposite direction.

If the grass is extremely high, mow twice at different cutting height settings.

Prior to starting

Fuel

As fuel, use unleaded petrol (see operating instructions of the engine manufacturer).

You can use E10 petrol. Do not store E10 petrol longer than 30 days.

Tanking up



Danger!

Fuel is ignited by hot engine parts.

Prior to filling up, switch off the engine and wait for at least 20 minutes until the engine has cooled down. Observe the safety instructions regarding the fuel!

Filling up with fuel

1. For filling, use a canister with filler spout or a funnel.
2. Open the canister carefully so that existing excess pressure is slowly reduced.
3. Open the tank cap carefully so that existing excess pressure is slowly reduced and no fuel sprays out.
4. Fill the fuel tank.
5. Tightly close the tank cap again.

Checking the engine oil level

Attention! Prior to each use, check the engine oil level (see operating instructions of the engine manufacturer).

Adjusting cutting height

Adjust the cutting height setting only when the engine is switched off.

Set the cutting height so that the blade does not touch the ground even in case of terrain unevenness. If the cutting height is set too high, objects can be ejected and the "clean cut appearance" can be destroyed.

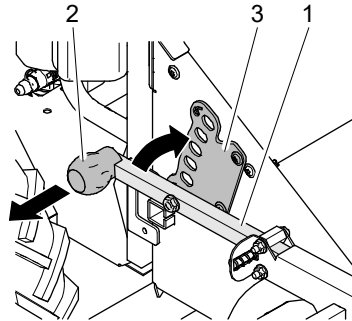

The cutting height can be set in 5 levels of 10 cm up to 110 cm.

1. Switch off the engine and wait until the blade comes to a standstill.
2. Pull the adjustment lever (1) with the knob (2) out of the notch (3) and let it lock in the desired position.

Starting



Danger!

During startup, there is a risk of injury caused by the rotating blade.

Make sure that no one is within the danger zone of the blade. Do not tip the device over to one side during startup.



Danger!

If after startup the carburetor does not close properly, fuel will overflow and a fire hazard occurs.

Close the fuel valve and contact an authorised service centre.

Starting the device (AS 901 SM)

1. Place the device on even terrain, not in high grass.
2. Close the fuel valve and the tank ventilation.
3. Plug in the plug connector.
4. Set the engine stop switch to "I".
5. With cold start, close the choke.
6. Turn the accelerator lever to medium engine speed.
7. Press the start button with your left thumb and continue to press it.
8. Pull the starter rope slowly out until you feel resistance and then pull out quickly – engine starts to run.
9. Slowly release the starter rope.
10. Release the start button.
11. Open the choke again.
12. For mowing, set the accelerator lever to the maximum speed.

Starting the device (AS 701 SM)

1. Place the device on even terrain, not in high grass.
2. Close the fuel valve and the tank ventilation.
3. Plug in the plug connector.
4. Set the engine stop switch to "I".
5. Set the accelerator lever during cold start to the position "Choke", otherwise to medium speed.
6. Press the start button with your left thumb and continue to press it.
7. Pull the starter rope slowly out until you feel resistance and then pull out quickly – engine starts to run.
8. Slowly release the starter rope.
9. Release the start button.
10. For mowing, set the accelerator lever to the maximum speed.

Engaging the blade

1. Lift the blade clutch lever.
2. Press the latch knob at the blade clutch lever.
3. Press the blade clutch lever towards the handlebar – the blade starts to move.

Disengaging the blade when moving over paths:

1. Release the blade clutch lever.

Oil pressure switch

The oil pressure switch ensures that the engine is not damaged when the device is used in steep terrain.

The oil pressure switch switches off the engine when damage to the engine may occur due to lack of oil pressure. This may occur when:

- Oil level is too low.
- The device is in too steep a sloping position while in steep terrain.

How steep the gradient for the oil pressure switch to switch off the engine may be depends on the engine type, direction of inclination, and the oil level.

In order to restart the engine, push the device while in idle state to terrain that is less steep. In every case, check the oil level.

Driving

Driving

In case of a hazardous situation, switch off the drive and declutch the blade.

Drive on:

1. Engage the desired gear.
2. Press the drive lever towards the handlebar - device is moving.

Drive off:

1. Release the drive lever.

Adjusting the driving speed:

The driving speed depends on the quantity and thickness of the growth. If the growth is especially high and thick, you can mow at low driving speed only.

1. Release the drive lever.
2. Engage the desired gear.
3. Press the drive lever back towards the handlebar – device is moving.

Reverse gear



Danger!

Risk of injury caused by slipping or tripping during moving in reverse or turning.

When moving in reverse, always switch off the blade!

Prior to switching on the reverse, make sure that path is free of obstacles. Especially when going over already mowed grass ensure safe footing.

1. Release the drive lever.
2. Disengage the blade.
3. Set the accelerator lever to medium speed.
4. Set the switching lever to reverse (**R**).
5. Press the drive lever towards the handlebar - device moves in reverse.

Steering and turning

To control the direction of travel, a steering brake is installed at each rear wheel. The steering brake works also when moving in reverse.

Moving to the right:

- Pull the right steering brake lever. The right wheel is braked.

Moving to the left:

- Pull the left steering brake lever. The left wheel is braked.

Moving straight ahead:

- If both steering brake levers are in rest position, both wheels rotate at the same speed.

Stopping:

- If both steering brake levers are pulled, the device stops.

Turn the device only on already mowed grass.

Pushing

1. Release the drive lever.
2. Put the gear in neutral.
3. Press the drive lever again towards the handlebar – device can be pushed or rolls.
4. To steer, pull the respective steering brake lever only slightly.

Switching off and parking



Caution!

On a slope, the device can roll away.

Put the device on even ground only or secure it against rolling away.

1. Release the drive lever.
2. Turn the accelerator lever to the lowest engine speed.
3. Turn the engine stop switch to "0".
4. Wait until the motor comes to a standstill before you step away from the device.
5. Close the fuel valve and the tank ventilation.
6. Pull off the plug connector.

Transport



Warning!

Risk of injury due to the heavy weight of the device. The device can fall over and fall down and cause severe injuries.

Observe the following notices.

Transport the device on a freight vehicle or a trailer which is designed for a carrying capacity of at least as great as the empty weight of the device.

Prior to transport, let the device cool down for at least 20 minutes. Close the tank ventilation and the fuel valve.

For transport, you can fold up the handlebar.

Loading

Use suitable ramps for loading that

- can carry the empty weight of the device + 200 kg.
- are wider than the device.
- have a slip-free surface.



Notice!

Risk of damage due to incorrect fastening of straps.

Fasten the straps only at the points shown in the figure.

Do not overtighten the straps.

1. Put the device in front of the ramps and make sure that the ramps
 - are as wide as the wheel gauge of the device.
 - are tightly secured to the platform.
 - are not steeper than 15°.
2. Carefully drive the device via the ramps onto the platform.
3. Secure the device against rolling, sliding, tilting, and fuel leakage. Use straps that support the weight of the device.

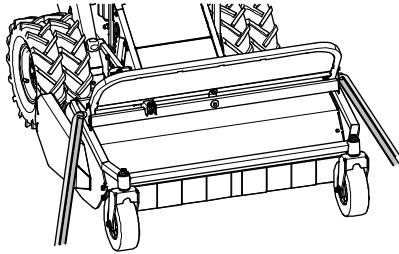
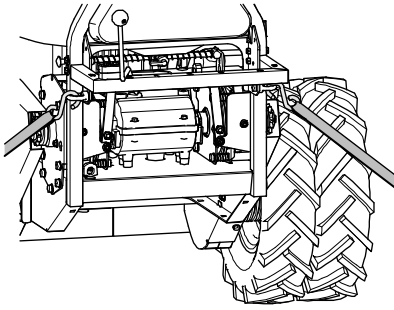

4. Secure the device with belts to the frame elements that can hold the weight

Unloading the device

1. Undo the transport fastenings.
2. Drive the device carefully down the ramps of the platform.

Maintenance



Warning!

Risk of injury due to unexpected movement. When inspections are carried out, the device can move unexpectedly.

Make sure that no persons or objects are in the danger area of the blade.

Make sure that no further hazards result from an unexpected movement.



Warning!

Risk of injury during maintenance and cleaning work when the engine is running.

Perform maintenance tasks only then with a running engine if this is required in the Maintenance table.

Improper maintenance can make the device unsafe for operation and result in accidents. Regular maintenance keeps your device ready for use.

Service the device according to the following maintenance instructions.

Contact an authorised service centre if problems during maintenance occur or if you determine deficiencies during one of the following inspections.

Prior to all maintenance and cleaning work when the engine is not running:

1. Let the device cool down for at least 20 minutes.
2. Pull off both plug connectors.
3. Close the fuel valve and the tank ventilation.
4. For work on the bottom of the device: Attach the front side of the device to a suitable lifting gear and pull the device up by crane until the engine mount rests on the ground.

Maintenance overview

Component	Action	Maintenance interval	
		A	B
Device	Check for safe working condition (basic inspection).	■	▲
	Clean.	■	
	Customer service.		▲
Fuel	Check fuel level.	■	
	Is the tank cap closed?	■	
Tank, fuel valve, and fuel line	Check parts for leaks and check for good condition.	■	▲
Carburetor	Does the carburetor close again after starting?	■	▲
Ventilation grid	Clean.	■	▲
Engine cooling	Clean.		▲
Spark plug	Check/replace.		▲
Air filter	Maintain.	■	■▲
Blade and fastening components	Check for wear and damage. See chapter Checking the blade.	■	▲
	Change.		▲
Motor brake	Does the blade stop within 7 seconds?	□	▲
Release the drive lever	Does the device stop when the lever is in zero position?	□	▲
Drive	Check.	■	▲
V-belt	Are the belts tensioned correctly, without fissures, and in good condition?		▲
Bowden cables	Check for proper function and ease of movement.	■	▲
Acceleration lever	Check for proper function.	□	▲
Chassis and impact protection	Check for rust and fissures and check the welding seams.	■	▲
	Are all protective devices and covers in place, fastened correctly and properly functioning?	■	▲
Label	Condition of the labels.	■	▲

Engine	For reliable information, see the operating manual of the engine manufacturer.	■	▲
	Check oil level (see operating instructions of the engine manufacturer).	■	▲
	Oil change.		▲
Bevel gear	Check the oil level.		▲
Parking brake	Check.	■	▲
Flammable material	Remove easily flammable debris buildup from the engine and the device.	■	▲
Tyres	Check tyres and, if necessary, the tyre pressure.	■	▲

A Before and after each use.

B Annually or every 50 h.

■ By the user when the engine is not running.

□ By the user when the engine is running.

▲ By the authorised service centre.

Cleaning the device

Depending on use, clean the device thoroughly, especially the bottom and the blade.

Grass cuttings and dirt that are stuck interfere with the grass ejection and impair the cutting quality. To sufficiently cool the engine, keep the engine cover, ventilation grid and engine clean.

Fire hazard! Take particular care that the components at the silencer are clean.

For cleaning, use a hand brush. Remove stubborn dirt with a wooden or plastic spatula. Clean the outside housing parts with a cloth.

Do not clean the device with water spray or high-pressure cleaner! Do not use any aggressive cleaning agents.

General inspection

To make sure that the device can be operated safely, check all nuts, bolts, screws, connections of fuel lines, air filters etc. regularly for proper condition and firm seating. Check the ignition wire and the spark plug connector for damage.

Immediately replace damaged or worn parts, especially covers, silencers or fuel tank (authorised service centre).

Check all parts that contain fluids for leaks and proper condition. These can be: Fuel tank, fuel valve, fuel lines, carburetor, engine, gears, battery, hydraulic system.

In case of leaks, contact an authorised service centre.

Chain lubrication

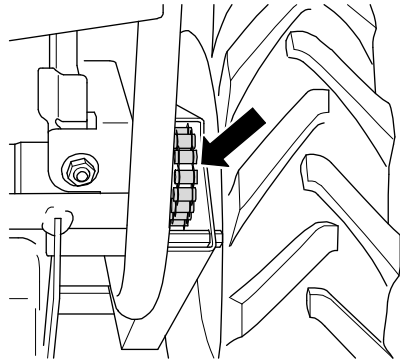

The chains to the right and to the left of the differential lock must be lubricated at regular intervals. We recommend using biodegradable chain spray.

Transmission

The transmission is maintenance-free and filled with oil that is supposed to last the entire service life of the device. Make sure that there are no leaks or damages.

Maintaining the engine



Danger!

If the speed of rotation is set too high, objects can be ejected. The engine can be damaged and noise pollution increases.

Do not change the basic setting of the carburetor or the speed control.

The engine manufacturer has prepared the operating manual of the engine. The manual contains all maintenance requirements and warranty conditions for the engine. If warranty work at the engine is required, contact your authorised service centre or the next authorised dealer for engines.

To ensure a long service life of the engine, sufficient engine cooling is required.

Keep the

- engine cover (ventilation grid),
 - silencer (protective grid) and
 - cooling fins of the engine
- clean at all times.

Checking the engine oil level

Never allow the oil level to be too low otherwise the engine can be damaged. Never fill in too much oil. Otherwise, there is the risk that the oil enters and destroys the air filter.

For this, observe the attached operating instructions of the engine.

Checking the spark plug



Danger!

The ignition system generates an electromagnetic field.

Wearers of pacemakers must not work on live parts.

Soiled spark plugs reduce the engine output. Clean the electrode of the spark plug with a brass wire brush. Check the electrode gap (see operating instructions of the engine manufacturer). Make sure that the insulator around the electrode is not damaged. Never use a damaged spark plug.

Tighten the spark plug using the correct torque (see operating instructions of the engine manufacturer).

Always check both spark plugs.

Maintaining the air filter



Danger!

Cleaning agents pose a fire and explosion hazard.

Never clean the air filter with flammable solvents.

Make sure that the air filter is always clean. A dirty air filter reduces the engine power and leads to increased engine wear and fuel consumption. Independent of the operating hours, change the filter insert at least once a year. Do not operate the engine without air filter.

For this, observe the attached operating instructions of the engine.

Checking the drive

1. Put the device on a non-slip surface (e.g. concrete or asphalt).
2. Switch off the engine.
3. Set the gear shift lever to a forward gear.
4. Actuate the drive lever.
5. Try to pull the device backwards.

If the rear wheels lock, the drive is correctly adjusted. If you can pull the device, the drive must be re-adjusted.

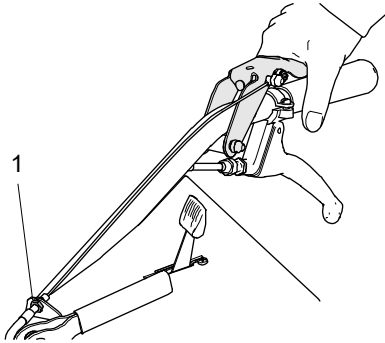

Re-adjusting the drive

Turn the adjusting screw (1) at the drive so that the wheels lock, while the drive is actuated, when the device is pulled. If there is no improvement after the adjustment, have the device checked by an authorised service centre.

Checking the parking brake



Danger!

If the parking brake is incorrectly adjusted, the device can roll away.

Make sure that the parking brake is always functioning properly.

1. Place the device on a surface with a good grip (e.g. concrete or asphalt).
2. Switch off the engine.
3. Turn the switching lever to idling.
4. Try to pull the device backwards.

If the rear wheels lock up, the parking brake is set correctly. If the device can be pushed, the parking brake must be readjusted by an authorised service centre.

Checking the blade



Danger!

Improperly mounted and maintained blades pose a severe injury hazard.

Work at the blade shall only be performed by an authorised service centre.



Use solid gloves when you check the blade.

Work at the blade requires specific expertise because an unbalance inspection is necessary and the torques must be observed.

Check the blade and all fastening elements for wear, damage and cracks

- each time before and after you mow.
- if there are noticeable changes.

All shown blade parts and their fastening elements must be changed

- if damage or cracks are detected.
- at least once a year or every 50 operating hours, no matter if wear does exist or not. The material weakens, can suffer cracks, endangering people and material assets.

Vibrations are an indication that

- the blade is worn excessively or on one side or
- damage to the engine or cutter deck fastening.

Blades that are sharpened improperly increase the workload of the devices and can result in vibration cracks or breaks.

Ejected broken pieces can cause severe injuries.

Changing the flail blades

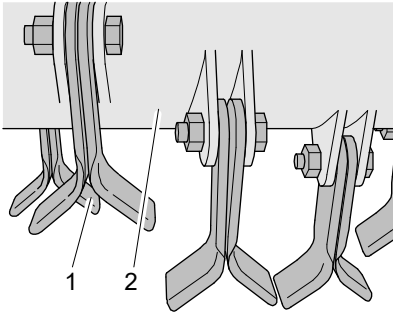

New blade

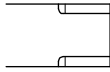

Replacing the blade

- broken

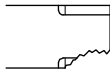

- bent



- worn on both sides

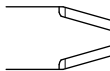

Turning over the blade

- worn on one side



The flail blades (1) can be mounted to both sides. Turn all flail blades over together when:

- one side is worn and
- when the other side of the flail blade has not yet been used.

Replace a flail blade when the blade is:

- broken,
- torn,
- bent or
- worn on both sides.

In case of uneven wear, there is a risk of imbalance.

Replace all flail blades together when more than 2 flail blades are damaged or worn.

For each blade change, check the flail shaft (2).

Always have a new spare blade ready.

Checking the fastening elements and the flail shaft



Danger!

Wear or damage at the flail shaft and the fastening elements can result in the flail blade or the fastening elements coming off.

Check the flail shaft, mounting plates, fastening screws and corresponding nuts of the flail blades.

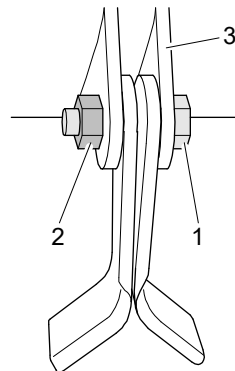

During mowing, the fastening elements wear. Replace the fastening screws (1) and the corresponding nuts (2),

- when their diameter is worn for more than 1 mm and
- during each blade change.

Use only original AS-Motor spare parts.

During each blade change, check the flail shaft for damages. The mounting plates (3) must not be damaged, bent, or worn. Contact an authorised service centre if damage, cracks or wear has occurred.

Checking the blade clutch

Check the blade clutch for proper function by disengaging the blade. The blade must come from full speed to a standstill in less than 7 seconds. Contact an authorised service centre if this is not the case.

Check oil level of the bevel gear.

Place the device for 30 minutes on a level surface before you check the oil level.

The ideal oil level is at the centre of the inspection glass.

If the oil level is below the bottom edge of the inspection glass, damage to the gearbox due to overheating will result. If the oil level is higher than 2/3 of the inspection glass, the seals will be damaged and oil loss will result.

Contact an authorised service centre when the oil level is too high or too low.

Assembly

Scope of delivery

The device is shipped in a carton.

The scope of delivery included:

- The device.
- This operating manual.
- Manufacturer's certificate.
- Tool bag.
- See operating instructions of the engine manufacturer

Unpacking

1. Open the box at the top.
2. Cut open the front side of the box.
3. Bring the handlebar up (see guide bar and handlebar).
4. Check the air pressure in the tires (see Technical data).
5. Switch the switching lever at the transmission to neutral position.
6. Press the drive lever towards the handlebar and push the device off the pallet.

Guide bar and handlebar

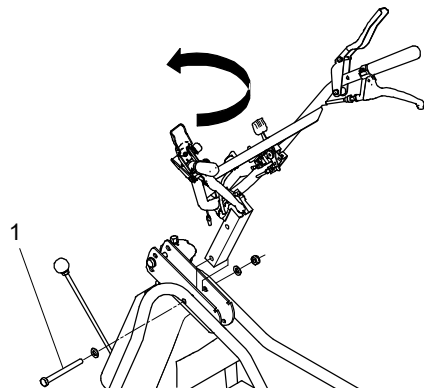

1. Slacken the screw (1) at the guide bar and pull it out sideways.
2. Turn the handlebar and guide bar to the correct position.
3. Fix the handlebar to the guide bar with the screw (1).

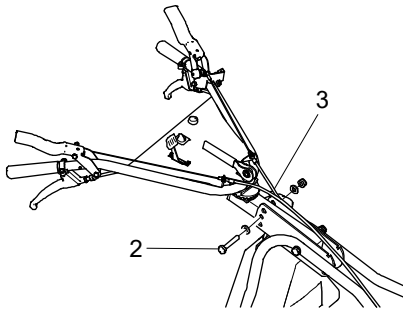

4. Slacken the screw for the height adjustment of the handlebar (2) and pull it out sideways.
5. **Attention:** Do not crush the Bowden cables (3) when swivelling the handlebar. Swivel up the handlebar to the correct working position and tighten with the screw and nut.

Storage

Storing the device

Keep the device in a closed, dry, and well ventilated room and out of reach of children. Always eliminate all problems of the device before you store it so that the device is always in a safe-to-operate state. Let the engine cool down before you store the device in closed rooms.

Longer storage

1. Observe the safety instructions regarding the handling of fuel.
2. Draining fuel tank: Put a piece of a tube on the fuel valve and fill the fuel in an adequate fuel container.
3. Emptying carburetor: Start the engine and let it run until it stops on its own.
4. Clean the device thoroughly.
5. Touch up defects in painting (for spray paint, see Accessories).
6. Preserve the engine:
 - Unscrew the two spark plugs.
 - Fill a tablespoon of engine oil into each spark plug opening.
 - Briefly actuate the starter (oil is distributed in the cylinder).
 - Screw the spark plugs back in.
 - Do not put the spark plug connector on!

In autumn, have your device checked by an authorised service centre!

Restarting

If you want to start the device after a longer storage, carry out the tasks described in chapter Maintenance.

Spare parts

The reliable and safe operation of the device also depends on the quality of the spare parts used. Only use original spare parts and accessories that were approved by "AS-Motor Germany". When foreign parts are installed, the warranty and guarantee shall be void for the foreign part and for the device and for any resulting damage.

Inform your authorised service centre about the device type and serial number of your devices when you order spare parts.

Wear parts

Some parts are wear parts. They wear during use and must be replaced. The warranty does not cover the following parts:

Blades, cutting blades, cutter bars, blade bolts, sliding plates, V-belt, chains, Bowden cables, starter ropes, pressure plates, air filters, spark plugs, disc springs, lock washers, fuses, discs, thrust plates, pressure discs, protection skirts, impact protection, wheels, tires.

Disposal

The device cuts and shreds the plant material in a single operation. Shredded plant material decomposes quickly, can be utilized as fertilizer, and, therefore, be left on the ground.

Dispose of waste oil and fuel in accordance with the local regulations or return it to an oil shop.

Packaging, device, and accessories are made of recyclable materials and must be disposed of accordingly.

Warranty

The conditions of the warranty can be found on the reverse side of your warranty card. Send the filled-out warranty card immediately after the purchase of your device to "AS-Motor Germany" or the supplier. Otherwise, the warranty is no longer valid.

Preserve the proof of purchase or the warranty card that was filled out by the vendor.

Troubleshooting

The following table contains the most frequent problems and their elimination. If more problems occur, contact the closest authorised service centre.

You can find an authorised service centre on our home page www.as-motor.de.

Problem	Possible cause	Remedy
Engine does not start	Engine stop switch is set to OFF.	Set engine stop switch to ON.
	Fuel valve is closed.	Open fuel valve.
	Tank ventilation screw is closed.	Open tank ventilation screw.
	No fuel is in the tank.	Refill fuel.
	Choke is open.	Close the choke.
	Spark plug connector is pulled off.	Observe the safety instructions! Put spark plug connector back on.
	Device was tilted – oil leaked into the air filter.	Replace air filter, unscrew spark plug and start several times when the fuel valve is closed, dry the spark plug and screw it back in.
	Engine was flooded due to too many start attempts.	Unscrew spark plug and start several times when the fuel valve is closed, dry the spark plug and screw it back in.
	Air filter is dirty.	Maintain air filter (see Maintenance).
	Spark plug is dirty, damaged, or incorrect electrode gap.	Clean spark plug and check electrode gap (see Maintenance). Replace spark plug if necessary.
	Housing of the mower is jammed.	See Maintenance.
	No oil pressure: Not enough engine oil.	Check engine oil level, refill.
	No oil pressure: Slope is too steep.	Bring the device to a level position.
	Poor quality, dirty, or old fuel.	Clean fuel system (authorised service centre). Always use fresh fuel.

Engine starts badly or runs irregularly	Choke is closed.	Open the choke.
	Air filter is dirty.	Maintain air filter (see Maintenance).
	Poor quality, dirty, or old fuel.	Always use fresh fuel.
	Spark plug is dirty, damaged, or incorrect electrode gap.	Clean spark plug and check electrode gap (see Maintenance). Replace spark plug if necessary.
No drive when drive lever is actuated	Drive belt is insufficiently tensioned.	See also Checking the drive.
The blade does not rotate	V-belt is insufficiently tensioned or damaged.	Authorised service centre.
	Bowden cable is defective.	Authorised service centre.
Strong vibrations during operation	Unbalance at the blade caused by incorrect sharpening or chips on the blade.	Have blade resharpened and balanced by an authorised service centre. Replace a damaged blade immediately.
	Blade drive shaft is bent due to collisions with foreign objects.	Authorised service centre.
	Engine fastening is loose.	Authorised service centre.
	Blade fastening is loose.	Authorised service centre.
Irregular noises	Loose fastening elements.	Authorised service centre.
	Silencer is defective.	Authorised service centre.
Engine is smoking	Air filter is dirty or drenched with oil.	Maintain or replace air filter (see Maintenance).
	Oil level is too high.	Have authorised service centre lower the oil level up to the marking.
Engine gets hot	Ventilation grid is dirty.	Clean ventilation grid.
	Oil level in the engine is too low.	Refill engine oil (see operating instructions of the engine manufacturer).
	Cooling fins of the engine are dirty.	Have cooling fins cleaned by authorised service centre.
Uneven cut, lawn becomes unsightly	Blade is dull or worn.	Have blade resharpened and balanced by an authorised service centre. Replace a damaged blade immediately.
	Speed is too high proportionately to the cutting height.	Reduce speed and/or select the correct cutting height.
	Housing of the mower is heavily contaminated.	Clean.
	Different tire pressure.	Check the tire pressure.

Mulching result with high plant material not satisfactory	Speed is too high.	Reduce speed.
Mulching result with low plant material not satisfactory	Plant material is ejected too quickly.	Increase speed.
Discharge channel is jammed	Mowed grass was too long or too damp.	Adjust cutting height and mowing speed to the mowing conditions.
	Blade is worn.	Authorised service centre.
	Engine speed is too low despite full power.	Authorised service centre.
The device does not stop when the brake is actuated	Brake is adjusted incorrectly, worn, or defective.	Authorised service centre.
The engine does not switch off	Switching off system is defective.	Close the fuel valve. Authorised service centre.
The tires become flat	Thorns or sharp objects damage the tires.	If necessary, use tire protection gel (authorised service centre).

Technical data

Type	AS 701 SM	AS 901 SM
Range of application (temperature)	0 - 30 °C For temperatures below 5 °C, observe the engine manufacturer's information regarding the engine oil.	
Engine, type	One cylinder four stroke engine	Two cylinder four stroke engine
Manufacturer	Briggs & Stratton	Briggs & Stratton
Type	Series 3 Intek	Vanguard, V-Twin
Cylinder capacity	344 cm ³	480 cm ³
Performance	7.6 kW (10.3 PS)	10.7 kW (14.5 PS)
Engine speed	3300 min ⁻¹	3500 min ⁻¹
Cutting device, type	20 Y-flails	26 Y-flails
Cutting width	70 cm	90 cm
Cutting height	10-100 mm	10-100 mm
Growth height	approx. 120 cm	approx. x cm
Starting device	Rope start	
Drive	Mech. transmission with differential lock	Mech. transmission with differential lock
Speed forward	1.1; 1.5; 2.4; 3.0; 3.6 km/h	1.2; 1.6; 2.6; 3.2; 4.0 km/h
Speed reverse	1.7 km/h	1.8 km/h
Maximum area coverage	approx. 2500 m ² /h	approx. 3600 m ² /h
Measures and weight		
Transport size with packaging L/W/H	195/112/110 cm	195/112/110 cm
Max. tyre dimensions L/W/H	220/84/105 cm	220/104/105 cm
Weight	196 kg	215 kg
Capacities		
Fuel tank	5 litres	5 litres
Engine oil	1.2 litres SAE 30 or 5W-40	1.4 litres SAE 30 or 5W-40
Bevel gear oil	0.25 litres Hypoid SAE 90-API-GL5	0.25 litres Hypoid SAE 90-API-GL5
Sound level, according to DIN EN 12733		
Measured sound level L _{WA}	102.0 dB	100.0 dB
Sound level at working place L _{pA}	91 dB	87 dB
Measurement uncertainty k	2.5 dB (A)	2.5 dB (A)
Vibration emission value according to DIN EN 12733		
Hand-arm-vibrations a _{n,W}	2.4 m/s ²	2.5 m/s ²
Measurement uncertainty U	1.5 m/s ²	1.5 m/s ²
Tyre pressure	1.0 - 2.0 bar	

Accessories

Spray paint 400 ml, colour orange:	G00011050
Operating hours counter:	G06927008
Clinometer:	G06950027
Hand protection set:	G06780309

Declaration of conformity

We declare that the flail mowers

Type	AS 701 SM	AS 901 SM
Cutting width	70 cm	90 cm
starting from serial no.	026817110001	026017110001

as brought into circulation by us conform to all relevant safety and health requirements of the EC directives listed.

- 2006/42/EG
- 2014/20/EU

Function:

The device is intended only for cutting grass or similar vegetation in well-maintained grounds, in agriculture, forestry and preservation of the countryside that are cut at least once a year.

Applied standards:

EN 12733

Place where all technical records are filed:

AS-Motor Germany GmbH & Co. KG
Ellwanger Straße 15
D-74424 Bühlertann

Bühlertann, January 2015



Eberhard Lange
Managing director



By proxy Frank Einsiedler
Head of development



THE HIGH GRASS MOWER AND 2 STROKE ENGINE MANUFACTURE

AS-Motor is your premium manufacturer for lawn and high grass mowers as well as 2 stroke engines. We offer our customers professional technology for steep slopes, rough terrain, and lawn care. Our extensive product range which includes hand-held entry-level devices up to the world's first all-wheel ride-on mower with remote control will always offer private customers, municipalities service providers the right product. For more than 55 years, we have been developing and producing with a high production depth in Southern Germany and supply our dealer network in more than 30 countries all over the world.

Mulching mower	Mulching mower – the time-saving alternative! AS-Motor mulching mowers shred the grass to create such a fine mulch, almost an "invisible" fertiliser, that sinks right away back into the lawn. Disposal of the cuttings is not required.
Professional lawn mower	Professional lawn mowers with rear discharge for all every requirement, even with all-wheel drive, brake and reverse gear.
Brush cutter®	An agile lawn mower for maintenance of extensive grassed areas. The Allmäher® reliably mows and mulches metre-high grass, brushes and weeds.
Flail mower	High grass with undergrowth, steep slope or extensive areas in unknown terrain? The movably mounted flail blades of the AS-Motor flail mower give way to rocks and obstacles and chop the cuttings several times over.
Ride-on brush cutter	If extensive areas, weeds and undergrowth up to 1.2 m, the AS-Motor all-wheel mowers are also perfect for steep and even extremely steep terrain. Ease of use and high area performance combined in one compact ride-on mower. For more safety, comfort and efficiency in difficult terrain we have developed the innovative and the world's first remote controlled ride-on mower.
Rotary mower	The cost-effective alternative to the cutter-bar mower. Also ideal for feed production. The grass is not shredded but deposited in straight rows as a windrow next to the machine.
Weed remover	Careful and chemical-free weed removal. The AS-Motor weed removers "WeedHex" mechanically clean paved areas and curb stones from growing weeds – quickly, safely, and efficiently.